

LEISTER®

English

 **Hilltop**
Over 45 Years' Experience

VARIANT

**700/702/704/
706/708**

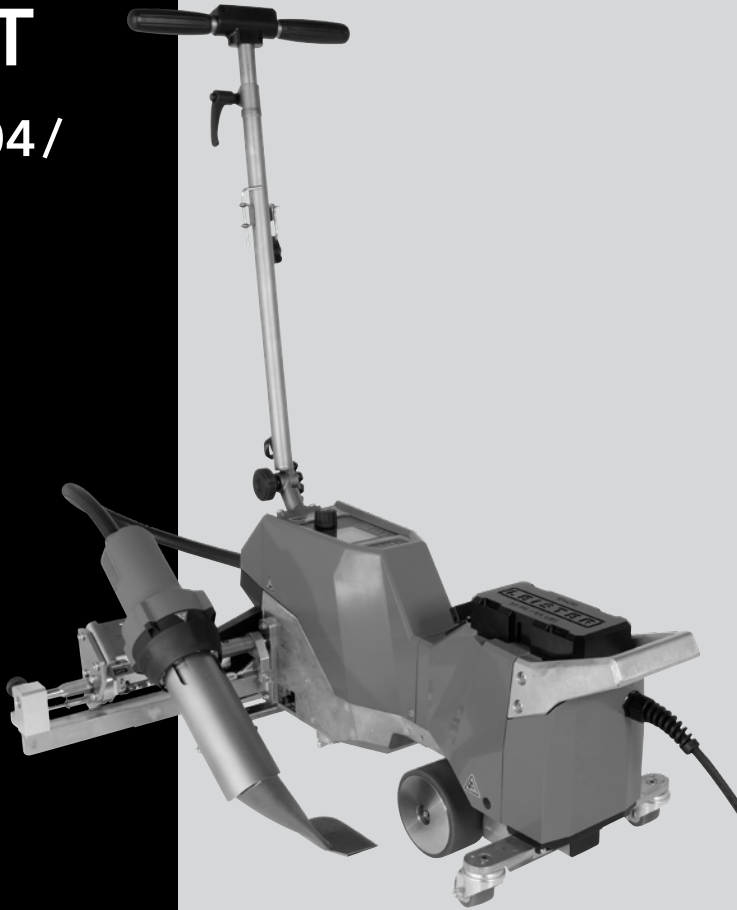

Hilltop Products

Unit A Parkside Business Park

Kirkstead Way

Golborne

WA3 3PY

+44 1942 723 101

Sales@Hilltop-Products.co.uk

Hilltop-Products.co.uk

Table of Contents

1. Application	4
1.1 Intended use	4
1.2 Non-intended use	4
1.3 General safety information	5
2. Technical data	6
3. Transport	7
4. Your VARIANT 70X	8
4.1 Type plate and identification	8
4.2 Scope of delivery (standard equipment in the case)	8
4.3 Overview of device parts	9
4.4 Overview of device versions	12
4.5 Application of the device versions	13
5. Settings on VARIANT 70X	14
5.1 Adjusting the welding nozzles	14
5.2 Additional weights for increasing the contact pressure weight	16
5.3 Adjusting the guide bar	16
5.4 Adjusting the movable castors	17
5.5 Converting the welding width overlap	17
5.6 Changing the drive unit	21
5.7 Change weld width for reinforcement tape	22
5.8 Removing the arm	23
5.9 Installing the arm	25
5.10 Park position	29
5.11 Track guide roller	30
5.12 Convert taper roller to anti-vandalism roller	30
5.13 Unwinding device	31
5.14 Converting the overlap drive	33
5.15 Floating nozzle	33
6. VARIANT 70X commissioning	34
6.1 Work environment and safety	34
6.2 Operating readiness	36
6.3 Starting the device	37
6.4 Welding sequence	37
6.5 Switching off the device/Maintenance	38
7. VARIANT 70X quick guide	39
7.1 Switching on/Starting	39
7.2 Stop/switch off	39

8. VARIANT 70X operating unit	40
8.1 Function buttons	40
8.2 Display	41
8.3 Setting the welding parameters	41
8.4 Display symbols of the status display (Display 40)	42
8.5 Display symbols of the work display (Display 41)	43
9. Settings and functions of the VARIANT 70X software	44
9.1 VARIANT 70X menu navigation overview	44
9.2 Basic setting	45
9.3 Formulas	45
9.4 Displaying set values	46
9.5 Eco-Mode	47
9.6 Advanced mode settings	47
9.7 Device settings	48
9.8 Info mode	51
9.9 Duty info	51
9.10 General Info	51
10. VARIANT 70X warning and error messages	52
11. VARIANT 70X FAQs, causes and measures	54
12. Accessories	55
13. Service and repair	55
14. Training	55
15. Declaration of Conformity	56
16. Disposal	56

Congratulations on your purchase of the VARIANT 70X.

You have chosen a first-class hot air welder.

It was developed and produced in accordance with the latest state-of-the-art technology in the plastics-processing industry. It has also been manufactured using high-quality materials.



Please always store these operating instructions with the device.

VARIANT 700/702/704/706/708

Hot-air welding machine

You can find more information on the VARIANT 70X at leister.com



1. Application

1.1 Intended use

The VARIANT 70X hot air welder is designed for use in the commercial sector for connecting technical and industrial textiles.

Welding procedures and types of materials

- Manually-guided hot air welder for overlap, hem, reinforcement, tape and piping welding of tarpaulins made of PVC, PE and other thermoplastic materials.
- For use in well-ventilated areas

The legal provisions on health protection applicable in the respective country must be observed. Never use the hot air welder in explosive or readily inflammable surroundings. Maintain sufficient distance from combustible materials or explosive gases at all times. Read the material safety data sheet from the manufacturer of the material and follow that company's instructions. Be careful not to burn the material during the welding process. Observe  general safety instructions [1.3].



- Only operate the device **under supervision** as waste heat can reach flammable materials.
- The device should only be operated by **trained specialists** or under their supervision.
- Children are not permitted to operate the device.

1.2 Non-intended use

Any other use or any use beyond the type of use described is deemed non-intended use.

1.3 General safety information

Please observe the safety instructions provided in the individual chapters of these operating instructions as well as the following safety instructions.

Warning



Risk of death from electric shock due to dangerous electrical voltage

- The device is only to be connected to sockets and extension cables with a protective earth conductor.
- Protect the device from moisture and wet conditions.
- When used on a construction site, a residual current circuit breaker is mandatory.
- Prior to using the device for the first time, check the power cord, the plug, and the extension cable for electrical and mechanical damage.
- The device may only be opened by instructed, qualified personnel.



Danger of fire and explosion with improper use in the vicinity of flammable materials and explosive gases.

- Avoid overheating of the material.
- Never place the device near combustible materials and/or explosive gases.
- Never place the device close to combustible materials and/or explosive gases while it is running and/or hot.
- Only use the device on fireproof surfaces.



Risk of burns due to hot equipment parts and hot air jet









- Do not touch the heating tube and nozzle when they are hot.
- Always allow the device to cool down first.
- Never point the hot air flow at people or animals.

Caution

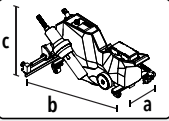

- The local supply **voltage** must match the nominal **voltage** specified on the device.
- Maximum network impedance according to EN 61000-3-11 / UL 499 / CSA C22.2 No 88: $Z_{max} = 0.169 \Omega + j 0.106 \Omega$. In case of doubt, the responsible electricity supply company should be contacted.

2. Technical data

		VARIANT 70X Overlap, Tape, AV 220-240V	VARIANT 70X Overlap, Tape, AV 400V	VARIANT 70X Reinforcement tape, DoubleAV 400V	
	Voltage	V~	230	400	
	Power	W	3680	5700	
	Frequency	Hz	50/60		
	Temperature	°C	100 - 620		
	Max. ambient temperature	°C	212 - 1148		
		°F	65		
	airflow	%	149		
			45 - 100		
	Drive	m/min	1.0 - 20		
		ft/min	3.2 - 65.6		
	Noise level	dB (A)	71 (K = 3)	74 (K = 3)	75 (K = 3)
	Weight	kg	24.3 - 31.1		
		lbs	53.6 - 68.6		
Dimensions 	a)	mm	562 (Overlap), 697 (Tape, AV)		
		inch	22.1 (Overlap), 27.4 (Tape, AV)		
			1059	41.7	
	b)	mm	800		
		inch	31.5		
			347	13.7	
	c)	mm			
		inch			
		 			

We reserve the right to make technical changes.

3. Transport



Risk of excessive physical strain when carrying and lifting the device

- Your VARIANT 70X including transport box weighs approximately 29–36 kg (approximately 24–31 kg without transport box and weight). **Two persons** are required to transport the machine with the transport box.
- For transport, use the transport box for the hot air welder that is included in the scope of delivery.
- Comply with applicable national regulations regarding the carrying or lifting of loads.



Fire hazard when transporting while hot

- The **hot air blower (12)** reaches temperatures of 620°C.
- Allow the **hot air blower (12)** to cool down sufficiently prior to transport (see Switching device off / maintenance [6.5]).
- Never store flammable materials (such as plastic or wood) in the transport box.



- Use the **front carrying handle (5)**, **rear carrying handle (6)** or the **guide bar (20–22)** on the device. The transport box is not suitable for transport with a crane, as there is a risk of device failure.

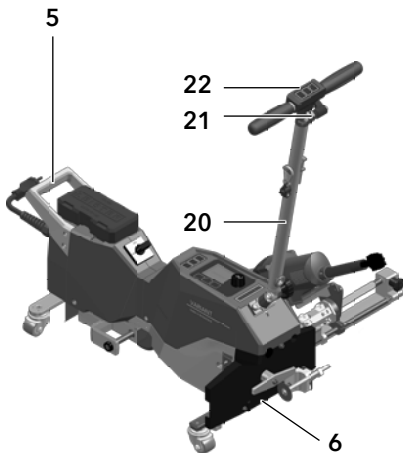

To lift the hot air welder by hand, use the **front carrying handle (5)** and **rear carrying handle (6)** or the **guide bar (20–22)**.

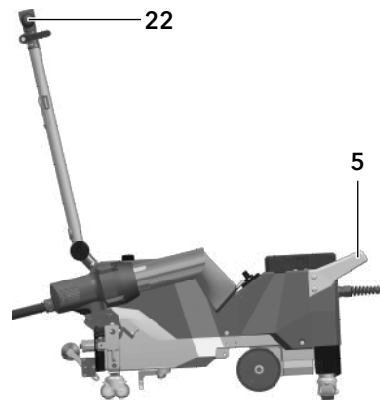

To position the hot air welder, guide the lifted appliance by the **guide bar (22)** or the **front carrying handle (5)** and roll the device into the desired welding position.

4. Your VARIANT 70X

4.1 Type plate and identification

The model and serial number are indicated on your device's **name plate (18)**.

Transfer this information to your operating instructions; in the event of any inquiries to our country subsidiary or your authorized Leister sales and service partner, please always refer to this information.

Model:

Serial no.:

Example:



4.2 Scope of delivery (standard equipment in the case)

1 x VARIANT 70X device

1 x auxiliary weight

1 x guide bar

1 x wire brush

1 x nozzle adjustment gauge

1 x hexagonal pin spanner, size 4

1 x Torx T20 screwdriver length 250 mm

1 x safety Instructions

1 x Quick Reference Guide

4.3 Overview of device parts

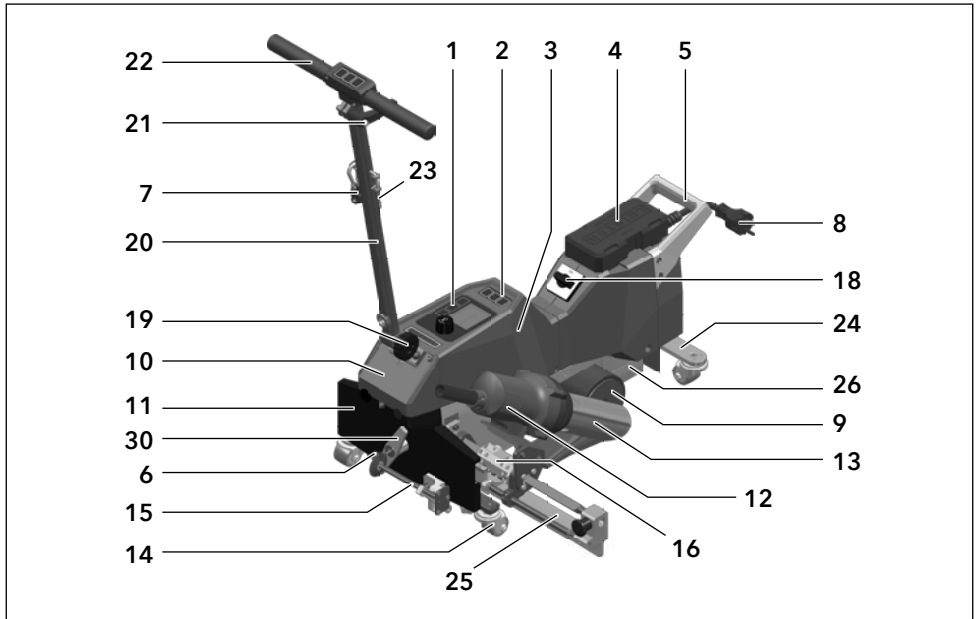

- | | |
|--|--|
| 1. Control panel | 22. Guide bar, top |
| 2. Keyboard | 23. Hexagon wrench key |
| 3. Housing | 24. Automatic lift-off |
| 4. Auxiliary weight | 25. Arm |
| 5. Front carrying handle | 26. Drive unit |
| 6. Rear carrying handle | 27. Air partitioning |
| 7. Holder for power cord (with carabiner for hanging) | 28. Unwinding device |
| 8. Power cord | 29. Material lifter |
| 9. Drive roller / contact pressure roller | 30. Manual swiveling out control lever |
| 10. Top cover | |
| 11. Bottom cover | |
| 12. Heat guns | |
| 13. Welding nozzle | |
| 14. Movable track roller | |
| 15. Track guide roller | |
| 16. Swivel mechanism | |
| 17. Type plate with model designation and series marking | |
| 18. Main switch (On/Off switch) | |
| 19. Locking screw (guide bar) | |
| 20. Guide bar, bottom | |
| 21. Clamping lever, guide bar, top part | |

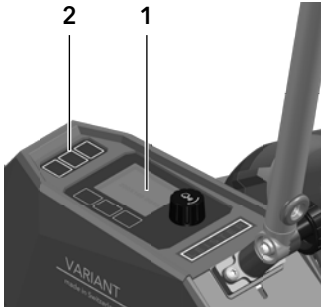

Control panel (1) & keypad (2)

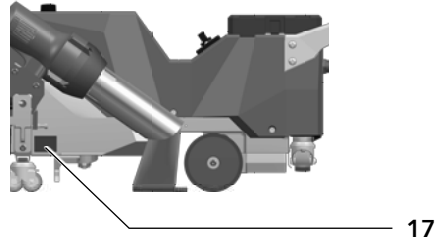

Type plate (17)

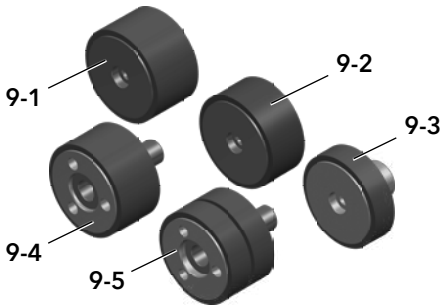

Pressure rollers (9-1 50 mm, 9-2 40 mm, 9-3 20 mm, 9-4 tape, 9-5 anti-vandalism)

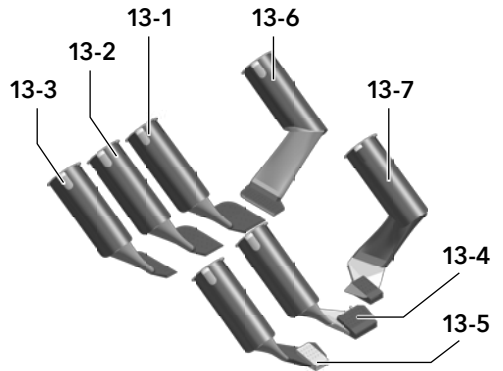

Nozzles (13-1 50 mm, 13-2 40 mm, 13-3 20 mm, 13-4 tape, 13-5 anti-vandalism, 13-6 20 mm mirrored, 13-7 anti-vandalism mirrored)

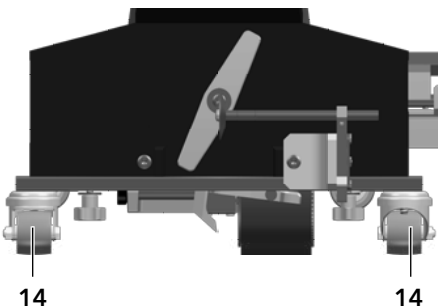

Movable track roller (14)

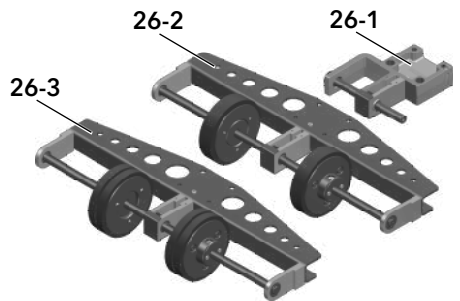

Drive unit (26-1) for overlap application, (26-2) for reinforcement tape application (26-3) for double anti-vandalism

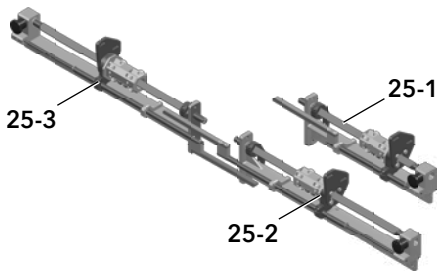

Extension arm RH short (25-1) for overlap and RH long (25-2) & LH (25-3) for reinforcement tape application

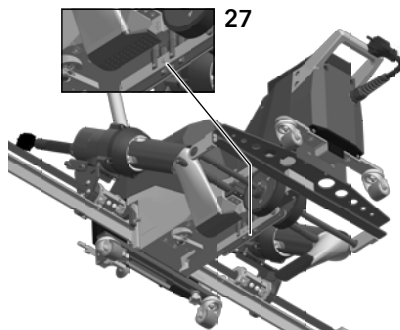

Air partitioning (27)

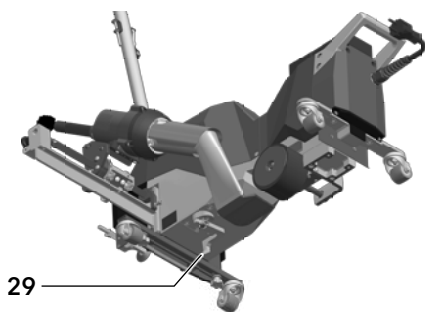

Material lifter (29)

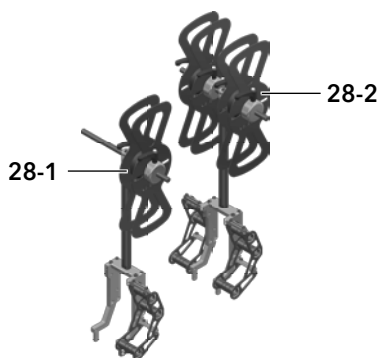

Unwinding device single (28-1) & double (28-2)

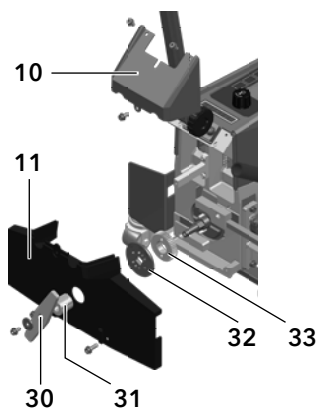

Parts swiveling mechanism

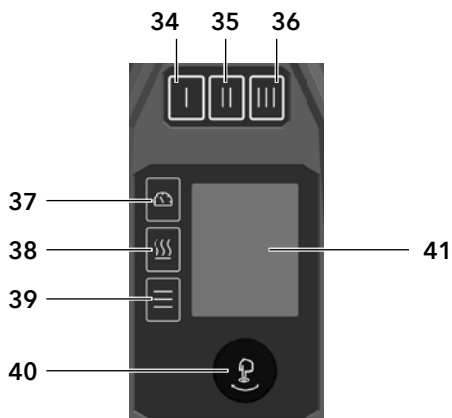

Operating unit

4.4 Overview of device versions

The following devices and combinations are available

No.	Version	Item no.	Base	Drive	Roller	Arm	Blower	Nozzle	Air partitioning	Dispenser
1	700	176.859	230V Schuko	Overlap (26-1)	50 mm (9-1)	RH short (25-1)	1	50 mm overlap (13-1)	-	-
2	700	175.860	230V Schuko	Overlap (26-1)	40 mm (9-2)	RH short (25-1)	1	40 mm overlap (13-2)	-	-
3	700	176.861	230V Schuko	Overlap (26-1)	20 mm (9-3)	RH short (25-1)	1	20 mm overlap (13-3)	-	-
4	700	176.862	230V CEE	Overlap (26-1)	50 mm (9-1)	RH short (25-1)	1	50 mm overlap (13-1)	-	-
5	700	176.863	230V CEE	Overlap (26-1)	40 mm (9-2)	RH short (25-1)	1	40 mm overlap (13-2)	-	-
6	700	176.864	230V CEE	Overlap (26-1)	20 mm (9-3)	RH short (25-1)	1	20 mm overlap (13-3)	-	-
7	700	176.865	400V CEE	Overlap (26-1)	50 mm (9-1)	RH short (25-1)	1	50 mm overlap (13-1)	-	-
8	700	176.866	400V CEE	Overlap (26-1)	40 mm (9-2)	RH short (25-1)	1	40 mm overlap (13-2)	-	-
9	700	176.867	400V CEE	Overlap (26-1)	20 mm (9-3)	RH short (25-1)	1	20 mm overlap (13-3)	-	-
10	702	176.869	230V Schuko	Overlap (26-1)	Tape (9-4)	RH long (25-2)	1	50 mm tape (13-4)	-	Single (28-1)
11	702	176.870	230V CEE	Overlap (26-1)	Tape (9-4)	RH long (25-2)	1	50 mm tape (13-4)	-	Single (28-1)
12	702	176.871	400V CEE	Overlap (26-1)	Tape (9-4)	RH long (25-2)	1	50 mm tape (13-4)	-	Single (28-1)
13	704	176.873	230V Schuko	Overlap (26-1)	AV (9-5)	RH long (25-2)	1	25 mm AV (13-5)	-	Single (28-1)
14	704	176.874	230V CEE	Overlap (26-1)	AV (9-5)	RH long (25-2)	1	25 mm AV (13-5)	-	Single (28-1)
15	704	176.875	400V CEE	Overlap (26-1)	AV (9-5)	RH long (25-2)	1	25 mm AV (13-5)	-	Single (28-1)
16	706	176.868	400V CEE	Reinforcement tape (26-2)	-	RH (25-2) & LH long (25-3)	2	20 mm overlap (13-3) & (13-6)	x (27)	-
17	708	176.877	400V CEE	Reinforcement tape (26-3)	-	RH (25-2) & LH long (25-3)	2	25 mm AV (13-5) & (13-7)	-	Dual (28-2)

4.5 Application of the device versions

The applications of the respective device versions are set out below:

Variant 700: Overlap applications. This version can be converted to a Variant 702 or 704 by replacing the pressure roller and fitting the unwinding device.

Variant 702: 50 mm reinforcement tapes. This version can be converted into a Variant 700 or 704 by replacing the welding nozzle and, if necessary, the pressure roller and, if necessary, removing the unwinding device.

Variant 704: 25 mm anti-vandalism tapes. This version can be converted into a Variant 700 or 704 by replacing the welding nozzle and, if necessary, the pressure roller and, if necessary, removing the unwinding device.

Variant 706: 20 mm baffle welding from 80 mm to 400 mm width. If 20 mm overlaps are to be welded with this version, the arm that is not required can be moved to the park position (chapter 4.4 Park Position [5.10]). This version can be converted to a Variant 708 by replacing the welding nozzle and fitting the unwinding device. This version can be converted into a Variant 700, 702 or 704 by removing an arm, replacing the drive unit and, if necessary, the nozzle and unwinding device. Depending on which arm is dismantled, a regular or a mirrored 700/704 version can be created. The drive unit can be mirrored for this purpose (chapter 4.4 Unwinding Device [5.13]).

Variant 708: Welding of two anti-vandalism tapes 150 or 200 mm apart. This version can be converted into a Variant 706 by replacing the welding nozzle and removing the unwinding device. This version can be converted into a Variant 700, 702 or 704 by removing an arm, replacing the drive unit and, if necessary, the nozzle and unwinding device. Depending on which arm is dismantled, a regular or a mirrored 700/704 version can be created. The drive unit can be mirrored for this purpose (chapter 4.4 Unwinding Device [5.13]).

The following conversion compatibility is available:

	700 (1-9*)	702/704 (10-15*)	706 (16*)	708 (17*)
Drive unit 26-1	x	x	x	x
Drive unit 26-2			x	x
Drive unit 26-3			x	x
Pressure roller 9-1, 9-2, 9-3	x	x	x (with 26-1)	x (with 26-1)
Pressure roller 9-4	x	x	x (with 26-1)	x (with 26-1)
Pressure roller 9-5	x	x	x (with 26-1)	x (with 26-1)
Nozzle 13-1, 13-2, 13-3	x	x	x	x
Nozzle 13-4, 13-5	x	x	x	x
Nozzle 13-6, 13-7			x	x

* See table in chapter 4.4 Device Versions (4.4)

5. Settings on VARIANT 70X

Note: There is also a video for all settings. See the how-to videos on Leister's YouTube channel.

5.1 Adjusting the welding nozzles

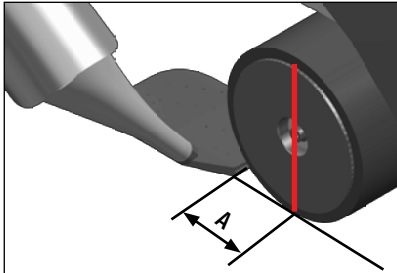

A = 45 mm +/- 2

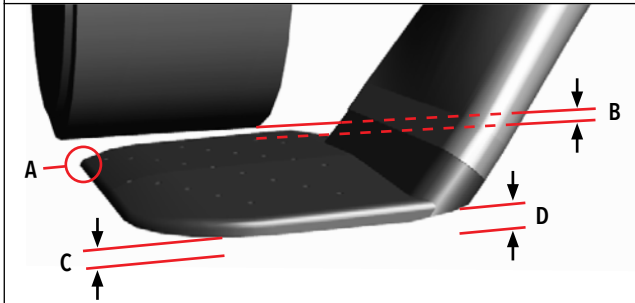

A = 0 mm
B = 1 mm
C = approx. 2 mm
D = approx. 3 mm

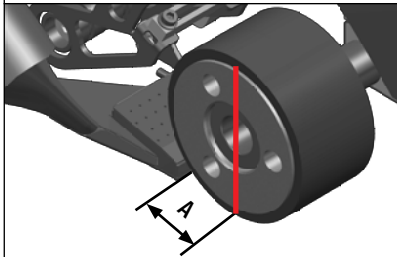

A = 42 mm +/- 2

Positioning the supplied nozzle adjustment gauge simplifies adjustment.

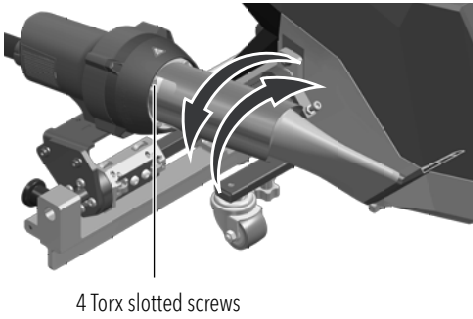
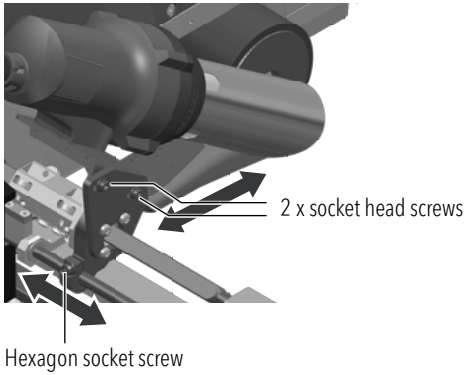
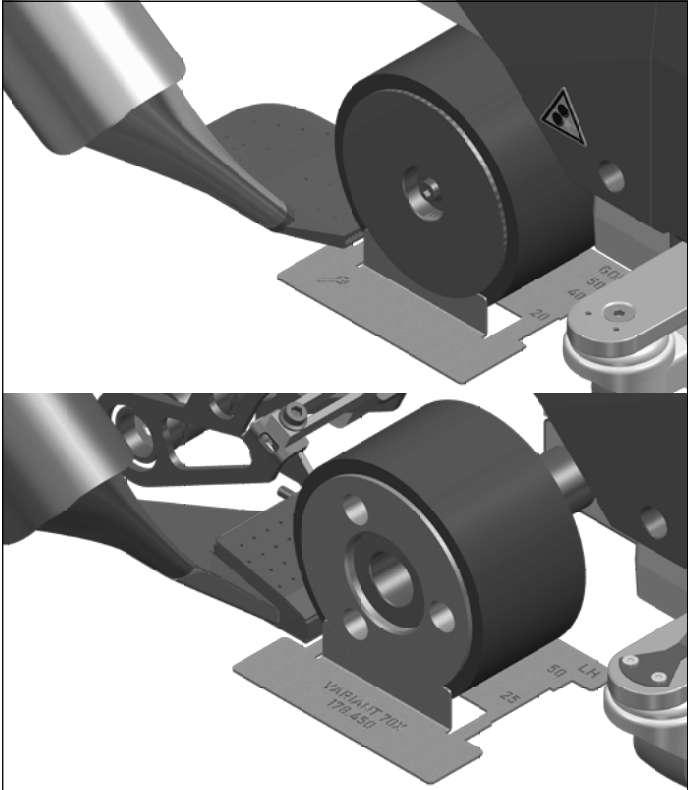

- Set dimension "A" (2 socket head screws)
- Set dimension "B" (4 Torx screws)
- Set alignment (Allen key)

5.2 Additional weights for increasing the contact pressure weight

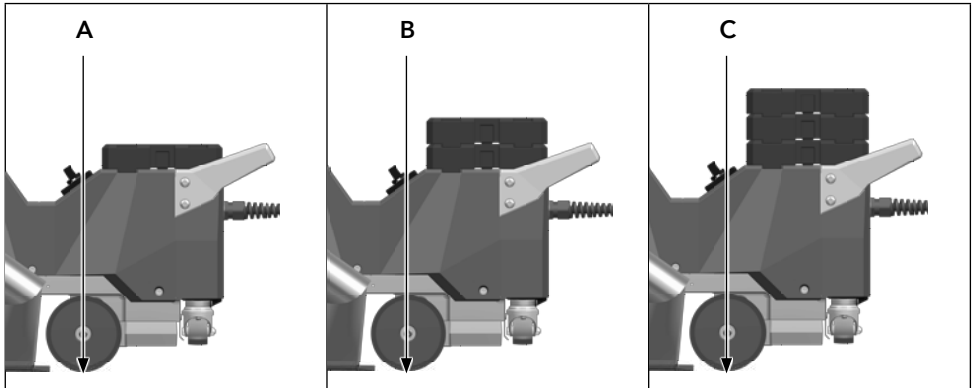

	Variant 700 40 mm	Variant 706
A	18.7 kg	22.5 kg
B	23.0 kg	26.9 kg
C	27.4 kg	30.9 kg

Maximum number of additional weights: 3 (= 9 kg)

5.3 Adjusting the guide bar

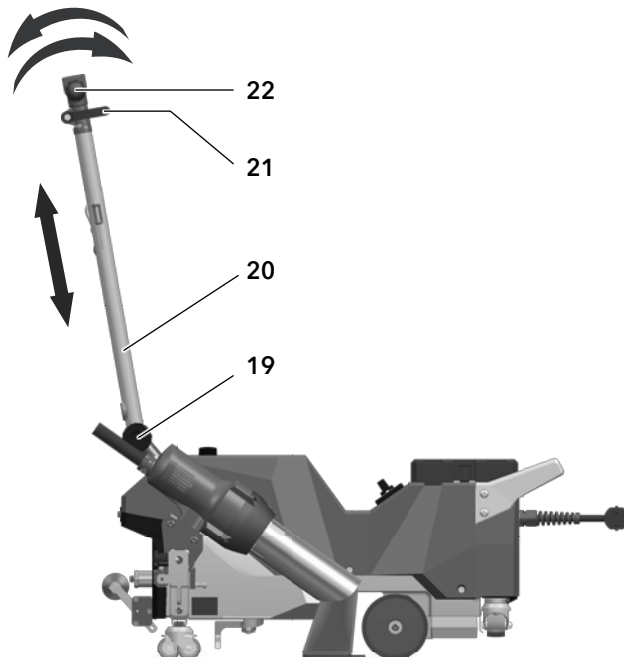

5.4 Adjusting the movable castors

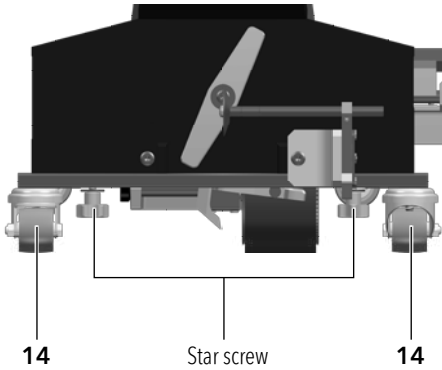

5.5 Converting the welding width overlap

pressure roller

1. Disconnect the power cord from the power supply
2. Loosen the fastening screw
3. Replace existing pressure roller with desired **pressure roller (9)**. Potential pressure rollers can be found in chapter [Overview of Device Parts \[4.3\]](#), possible combinations in chapter [Overview of Device Versions \[4.4\]](#).
4. Tighten the fastening screw

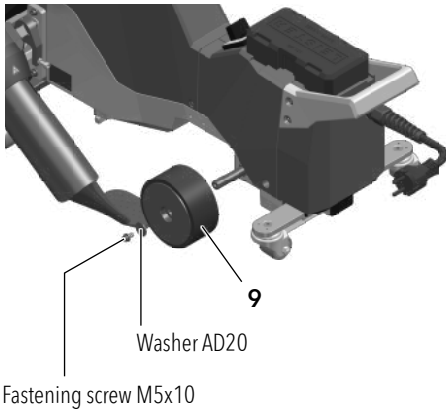

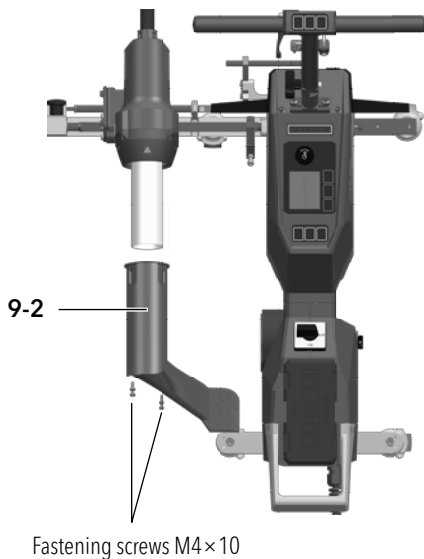

Nozzle

5. Loosen the welding nozzle fastening screws.
6. Replace existing nozzle with the desired **welding nozzle (13)**. Potential pressure rollers can be found in chapter [Overview of Device Parts \[4.3\]](#), possible combinations in chapter [Overview of Device Versions \[4.4\]](#).
7. Adjust nozzle with nozzle gauge, chapter [Adjusting the Welding Nozzles \[5.1\]](#).
8. Tighten the fastening screw.

Set welding width

9. Remove fixing screw **A** and **control lever (30)**.
10. Loosen fastening screws **B** and **remove track guide (15), top cover (10), then bottom cover (11)**.

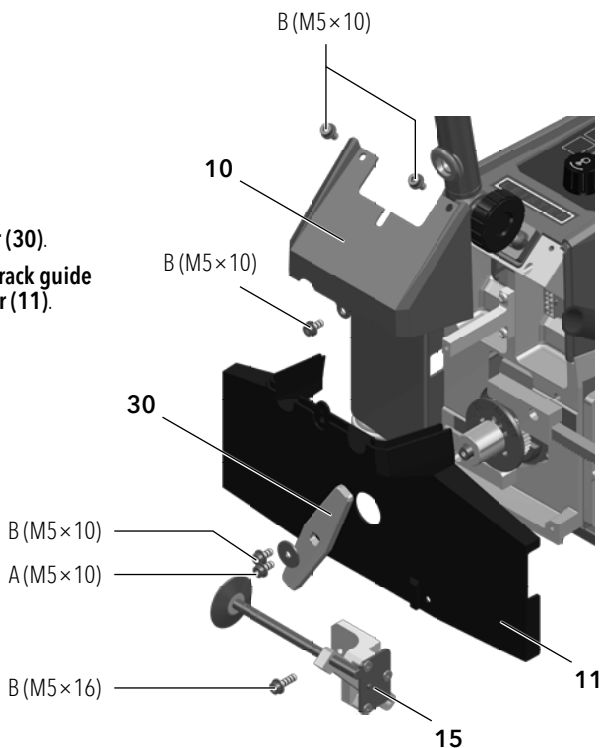

11. **Remove the spacer sleeve (31)** and pull out the **adjustment wheel (32)** slightly so that the drive pins no longer engage.

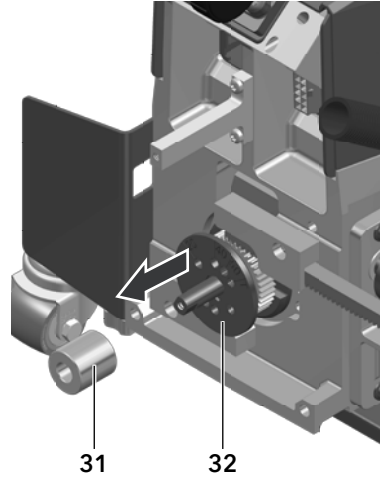

12. **Position the operating lever (30)** and turn it until the drive pins match the positions on the **adjustment wheel (32)**. Then push the adjustment wheel back again.

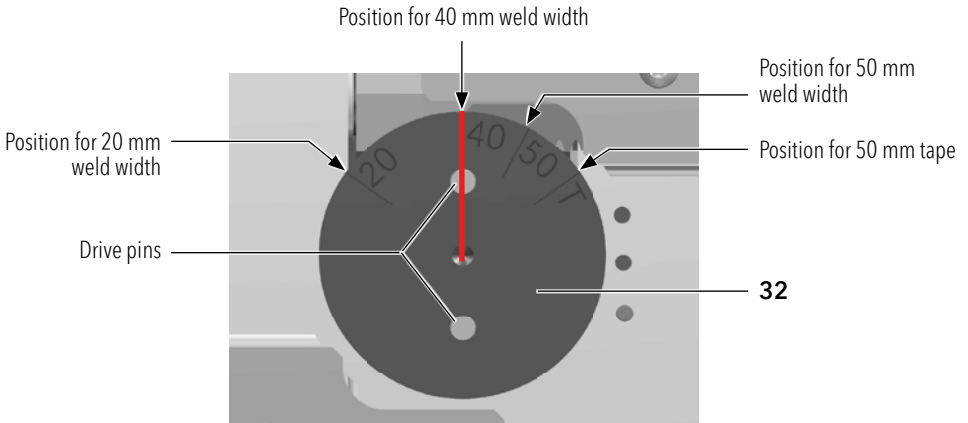
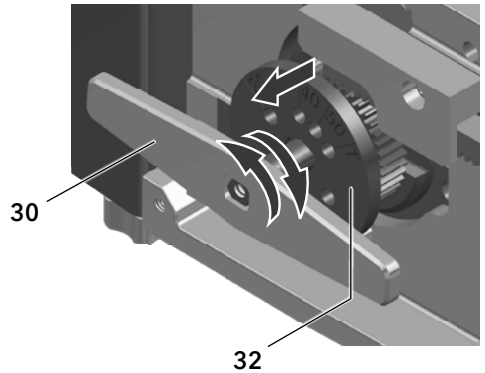

13. Push back the adjustment wheel (32) and fit the spacer sleeve (31).

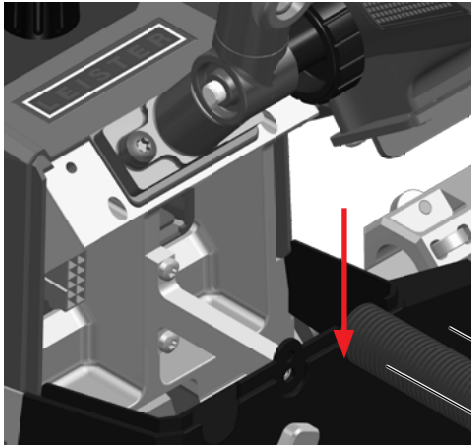
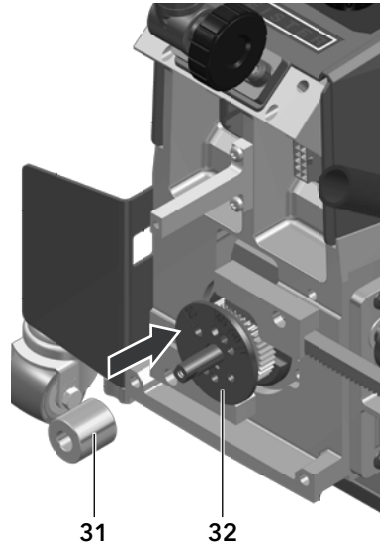

14. **Fit the bottom cover (11)** and hook on the corrugated tube.
15. **Fit the top cover (10)** and tighten the fastening screws **B**. Make sure that the spiral cable from the guide bar is sitting securely in the cover groove and is not pinched.
16. **Fit the operating lever (30)** and tighten fixing screw **A**.

11

Corrugated tube

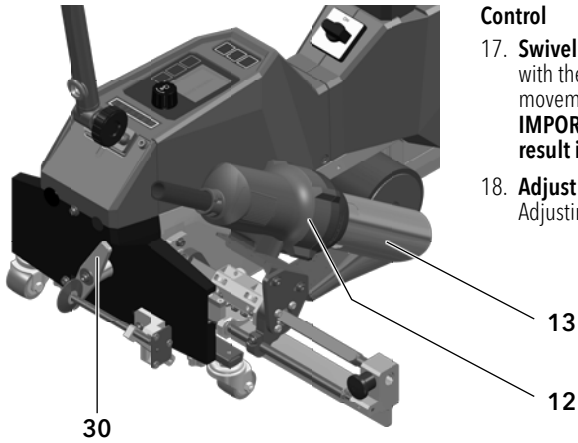

Control

17. Swivel the hot air blower (12) in and out once with the control lever (30) to check the correct movement range and freedom of movement.
IMPORTANT: Failure to perform this step may result in damage to the device.
18. Adjust the welding nozzle (13) (see chapter  Adjusting welding nozzles [5.1]).

5.6 Changing the drive unit

1. Disconnect the power cord from the power supply.
2. Loosen the fastening screw.
3. Replace the existing drive unit with the desired **drive unit (26)**.
4. Tighten the fastening screw.

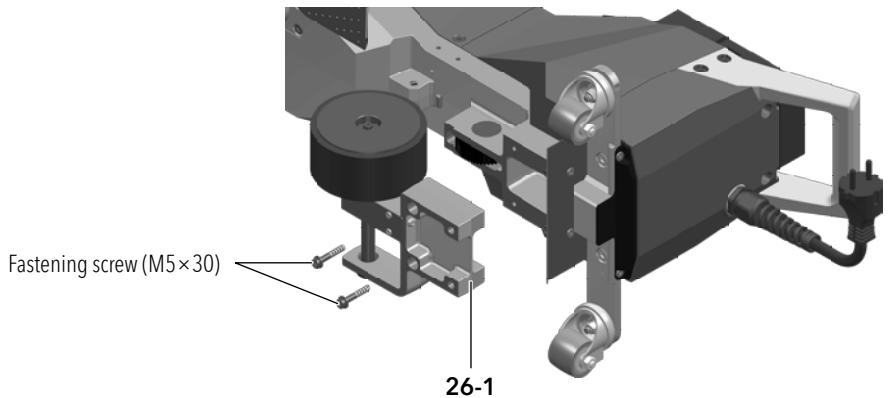

5.7 Change weld width for reinforcement tape

1. Disconnect the power cord from the power supply.
2. Loosen fastening screws **A** and **B**.
3. Set the drive roller to the desired welding width (the outer edge of the silicone must fit the scale) and tighten fastening screw **A**.
4. **Push the air partitioning (27)** up to the drive roller (should fit snugly without deforming) and tighten fastening screw **B**. If necessary, extend shaft using additional element.

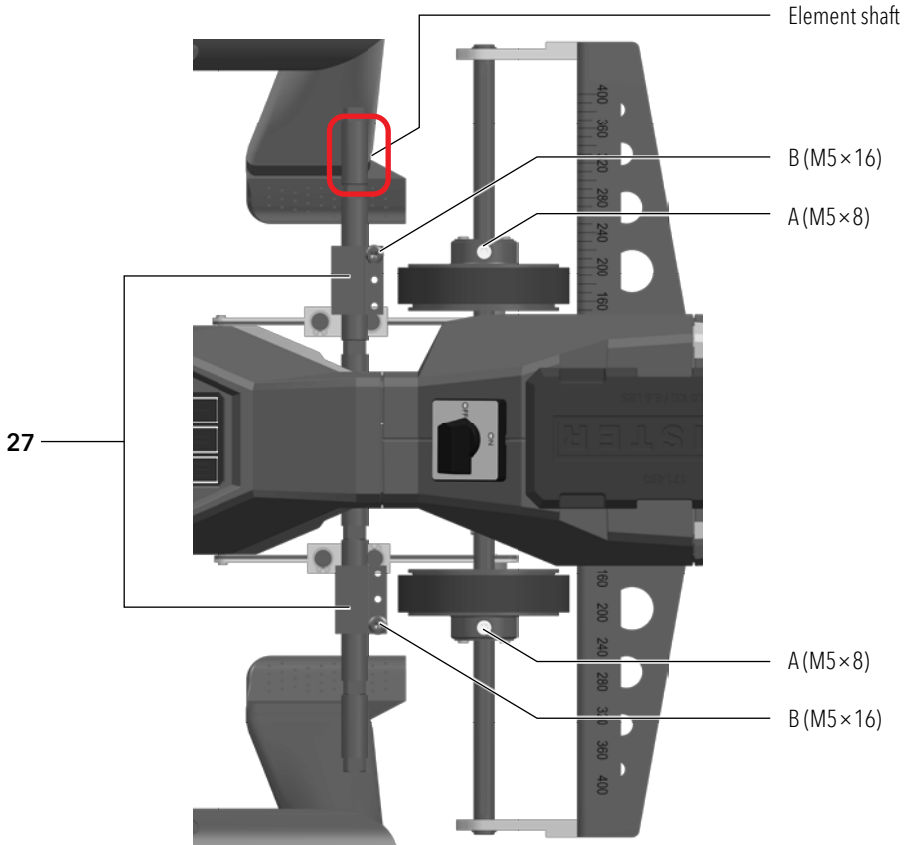

5. **Adjust the welding nozzle (13)** (see chapter  Adjusting welding nozzles [5.1]).
6. **Swivel the hot air blower (12) in and out once** with the **control lever (30)** to check the correct movement range and freedom of movement. **IMPORTANT: Failure to perform this step may result in damage to the device.**

5.8 Removing the arm

1. Disconnect the power cord from the power supply.
2. Ensure that the **hot air blower (12)** is swiveled out.
3. Move the arm shaft into the transport position. To do so, press lightly on the rear of the blower (so that the blower does not sink) and remove the locking bolt. Then push the shaft outwards until the locking bolt engages.

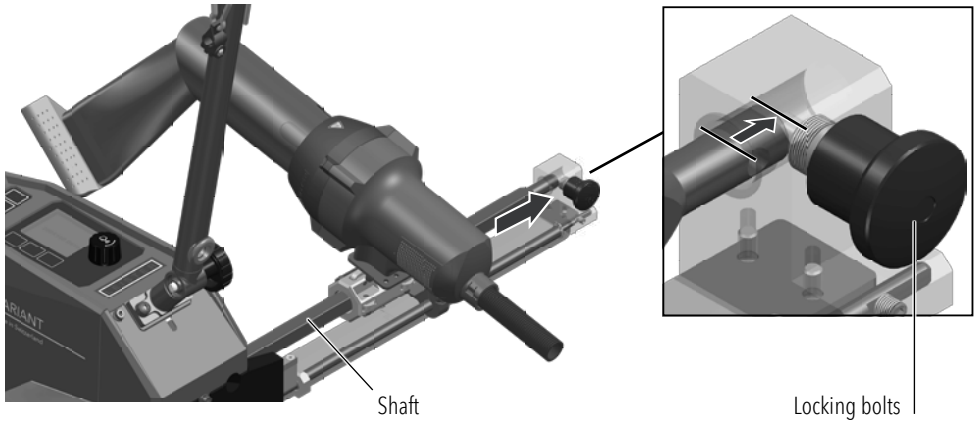

4. Move the hot air blower all the way out.

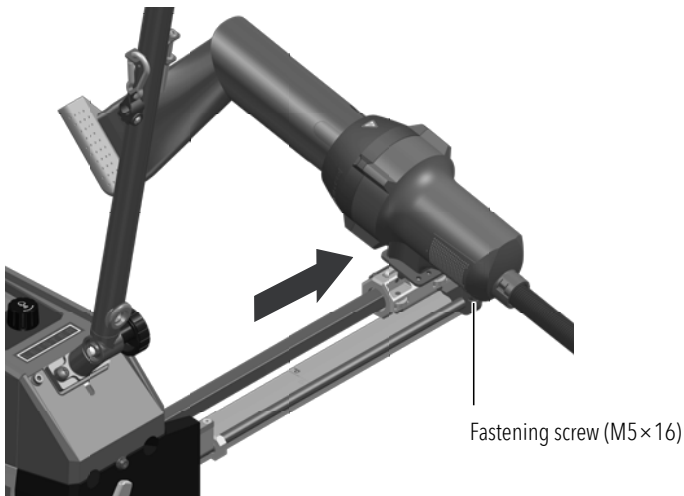

5. Remove fixing screw **A** and **control lever (30)**.
6. Loosen fastening screws **B** and **remove track guide (15), top cover (10), then bottom cover (11)**.

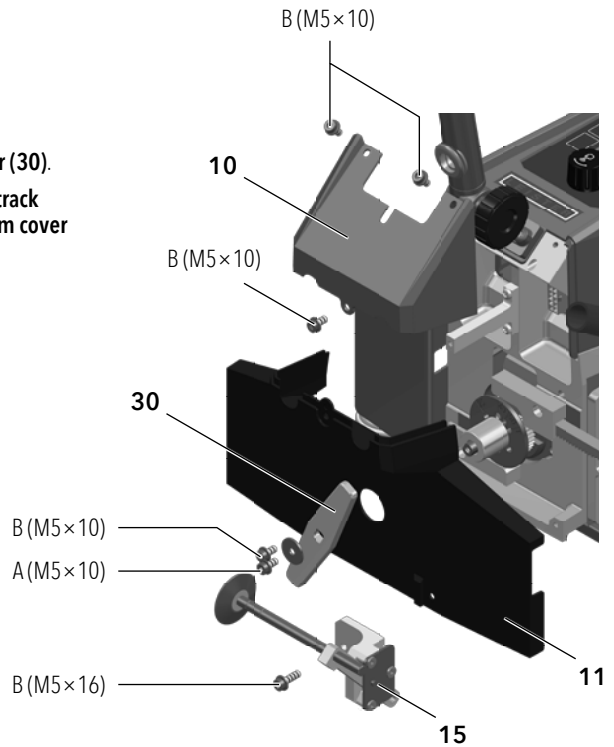

7. **Remove the spacer sleeve (31), adjustment wheel (32) and gearwheel (33)**. If the **gearwheel (33)** jams, lever it off evenly on both sides using a flat-blade screwdriver (right-hand image).

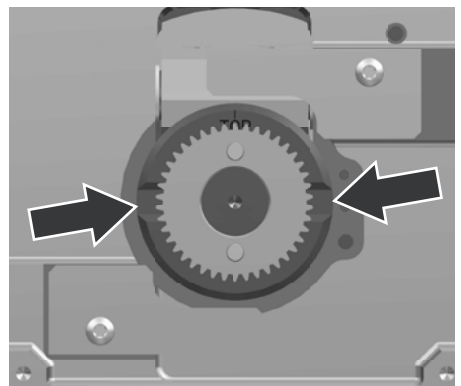
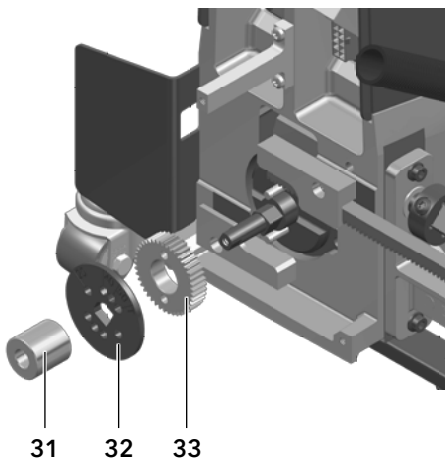

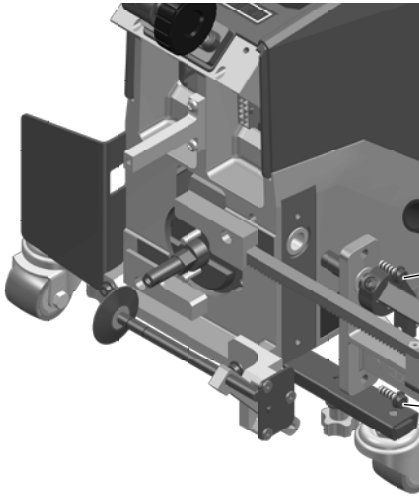

8. Disconnect the hot air blower's plug from the device.
9. Loosen the fastening screws and remove the bracket.

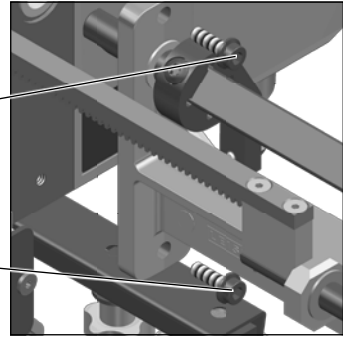

Fastening screws (M5×16)

5.9 Installing the arm

1. Perform steps 1-5 in chapter [Dismantling the Arm \[5.8\]](#).
2. Ensure that the outer shaft is set to "TOP".

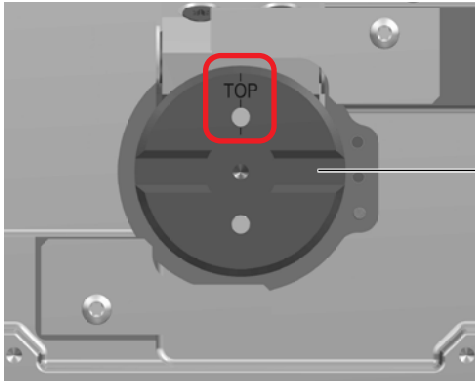

Outer shaft

3. Loosen the transport position of the new arm and mount it on the appliance using the fastening screws. Ensure that the gear rack is seated in the corresponding guide!

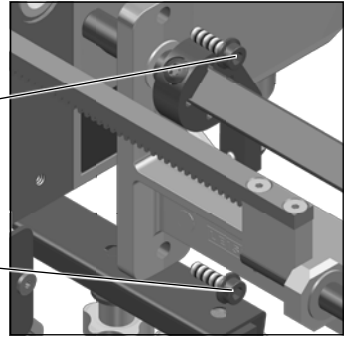
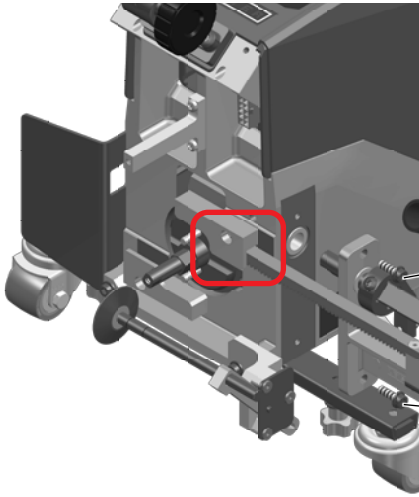

Fastening screws (M5×16)

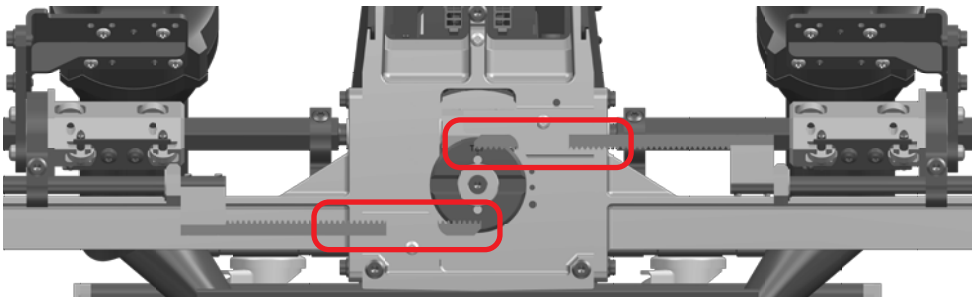

4. Connect the hot air blower's plug to the device. **CAUTION:** to avoid damaging the device, make sure that the plug is fully inserted as far as it will go (audible 'click').
5. Push gear racks all the way out.

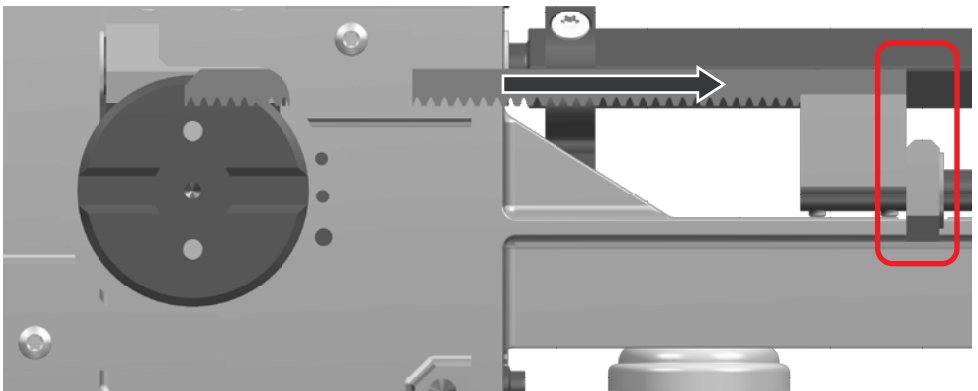

6. **Install gearwheel (33).** If the teeth are not aligned with the gear rack, push the gear rack slightly inwards. Do not force alignment of the teeth! Shift by a maximum of one tooth.

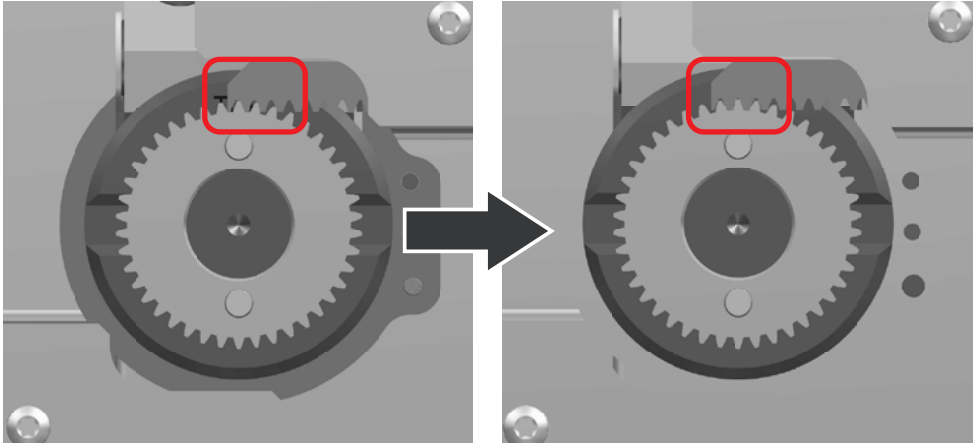

7. **Position the operating lever (30)** and turn it until the drive pins match the positions of the new welding width on the **adjustment wheel (32)**. Then push the adjustment wheel back again.

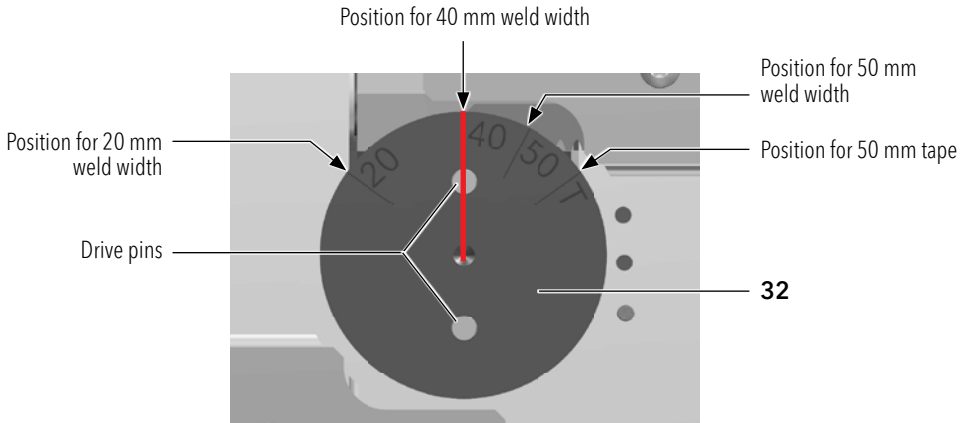
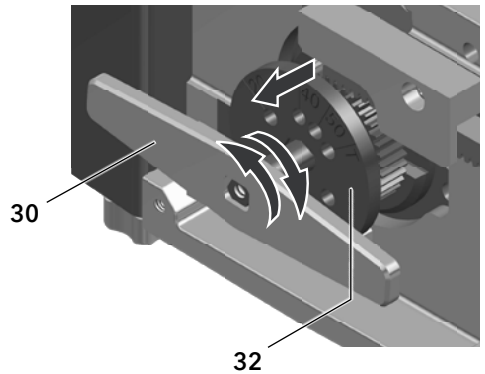

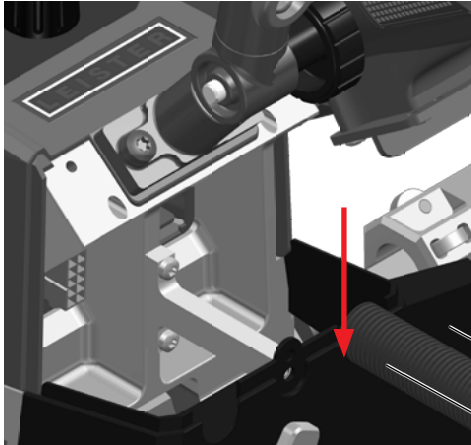

8. **Push back the adjustment wheel (32) and fit the spacer sleeve (31).**
9. **Fit the bottom cover (11) and hook on the corrugated tube. Fasten the cover with fastening screws B together with track guide roller (15).**

11

Corrugated tube

10. **Fit the top cover (10) and firstly tighten fastening screws C then fastening screw D. Make sure that the spiral cable from the guide bar is sitting securely in the cover groove and is not pinched.**
11. **Fit the operating lever (30) and tighten fixing screw A.**
12. **Swivel the hot air blower (12) in and out once with the operating lever (30) to check the correct range of movement and freedom of movement. **IMPORTANT: Failure to perform this step may result in damage to the device.****
13. **Setting the welding nozzle (13) (see chapter  Setting the Welding Nozzles [5.1])**

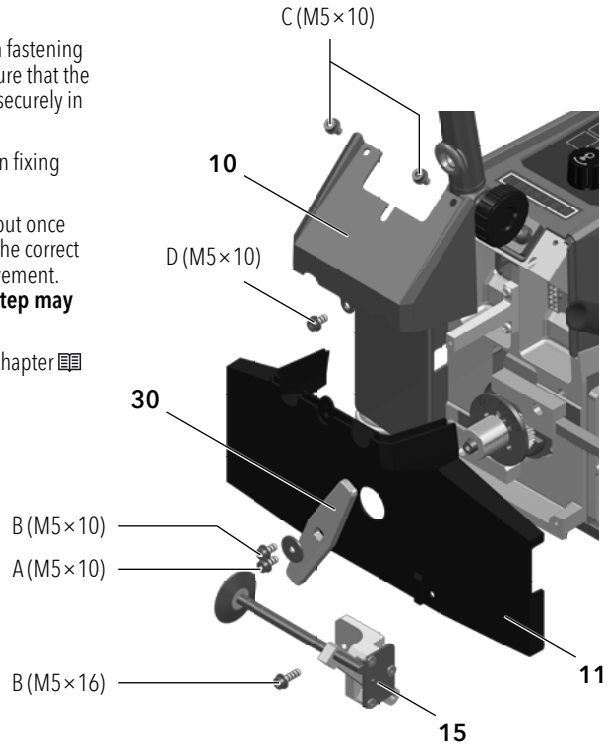

C (M5×10)

10

D (M5×10)

30

B (M5×10)

A (M5×10)

B (M5×16)

11

15

5.10 Park position

1. Disconnect the power cord from the power supply.
2. **Swivel the hot air blower (12) in** using the **operating lever (30)**.
3. **Move the hot air blower (12) to park position.**

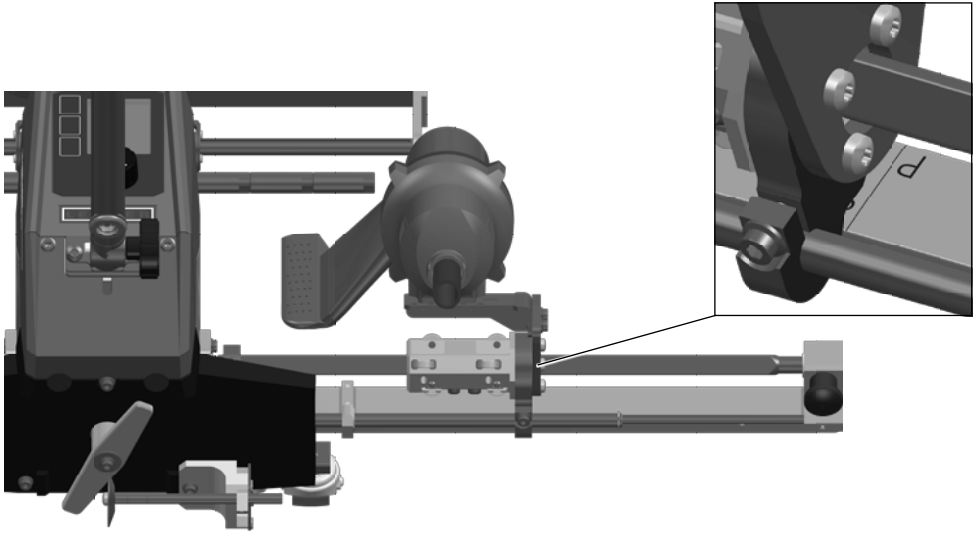

4. **Swivel the hot air blower (12) out** using the **operating lever (30)**.
5. Move the arm shaft into the transport position. To do so, press lightly on the rear of the blower (so that the blower does not sink) and remove the locking bolt. Then push the shaft outwards until the locking bolt engages.

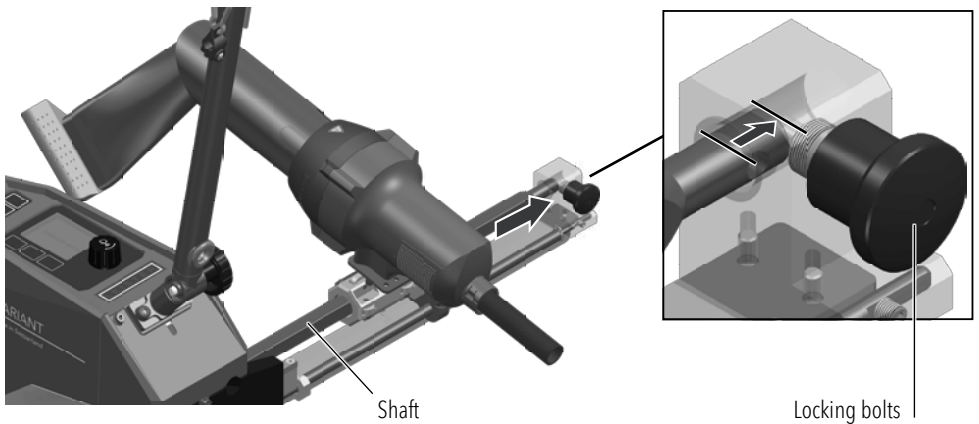

6. **Swivel the hot air blower (12) in and out once with the operating lever (30) to check the correct range of movement and freedom of movement. IMPORTANT: Failure to perform this step may result in damage to the device.**

5.11 Track guide roller

1. Loosen the fastening screw, slide the track guide roller into the desired position and tighten the fastening screw again. Align the groove in the shaft with the outer surface of the support.

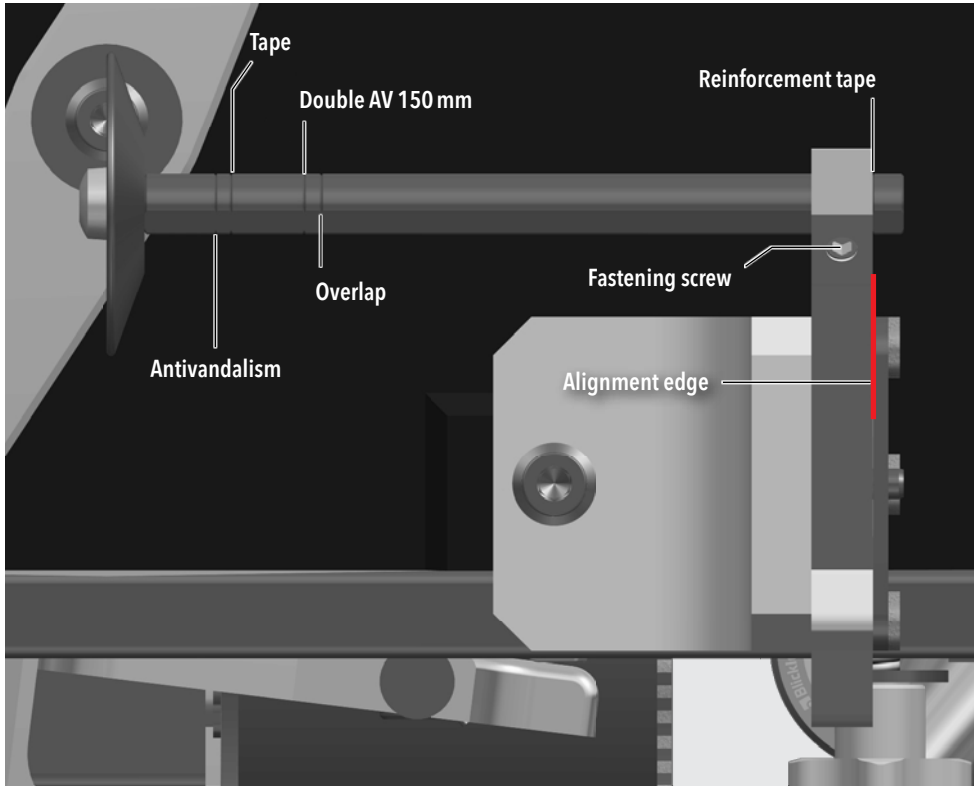

5.12 Convert taper roller to anti-vandalism roller

1. Loosen two of the three connecting screws of the roller halves and remove the third.
2. Pull the roller halves apart and insert the spacer discs.
3. Tighten the connecting screws.

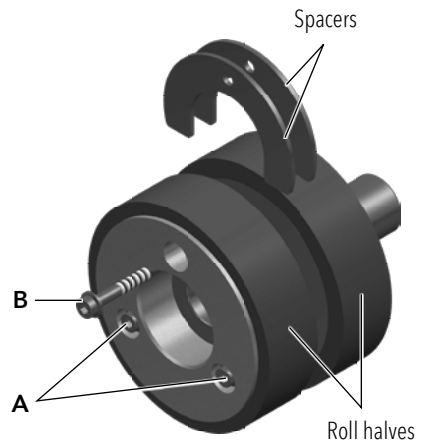

5.13 Unwinding device

1. Fasten the halves of the unwinding device to the machines using fastening screws **A**. Connect both halves together using fixing screw **B**.

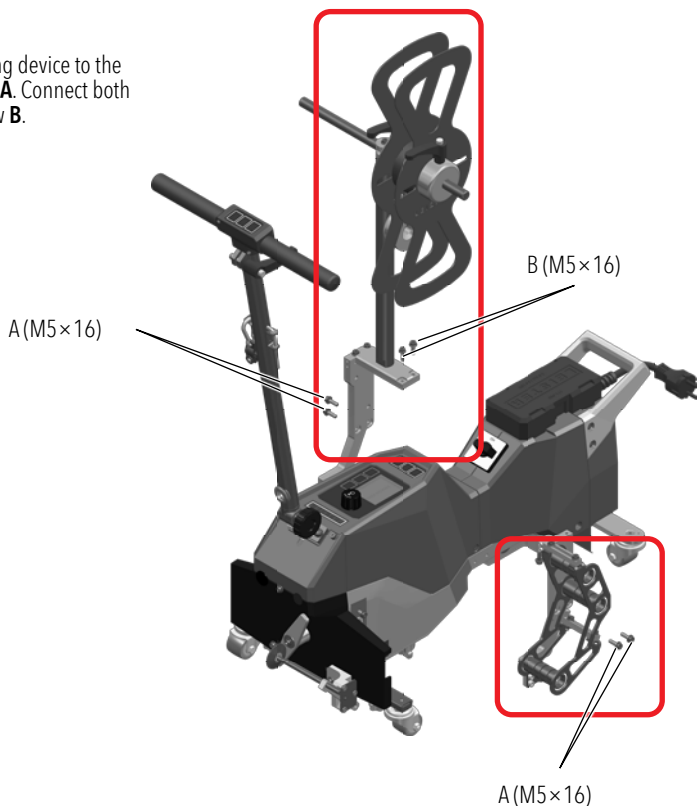

2. To adjust belt width, loosen the fastening screws and adjust the guide plate to the desired position.

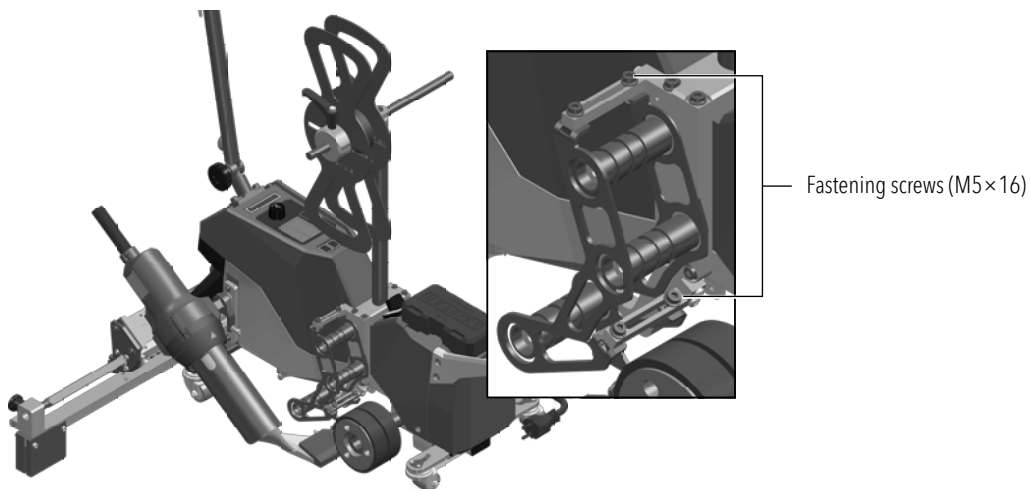

There are three grooves on the guide rollers for the unwinding device. These grooves are designed for the steel cores of the anti-vandalism hinges. The following illustration shows which groove is intended for which welding application. Left for the VARIANT 704, right for the VARIANT 708.

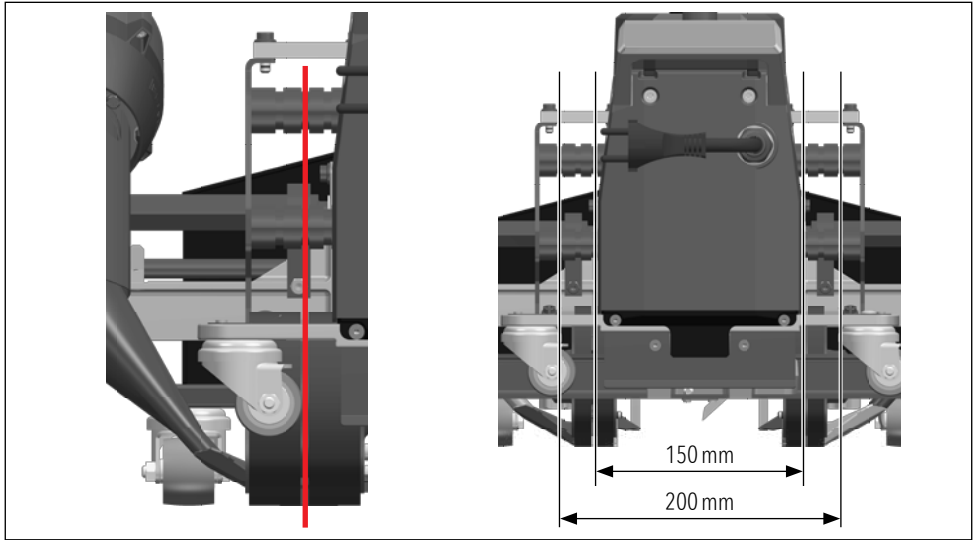

With the VARIANT 702, it is possible to raise the nozzle. To do so, loosen the fastening screws and move the stop plate to the desired height.

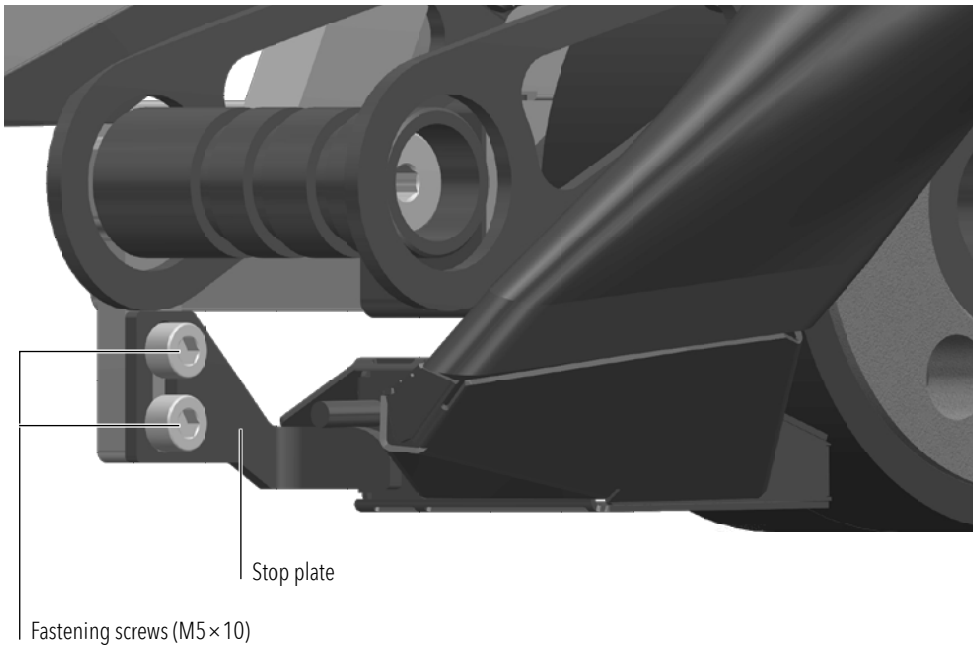

5.14 Converting the overlap drive

Fastening screw M3x6

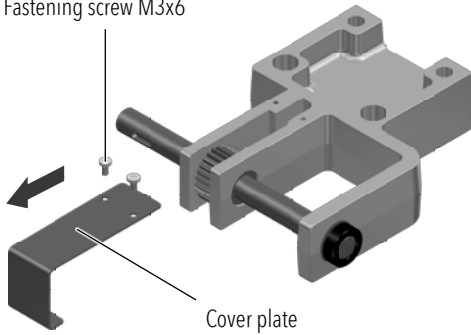

If a VARIANT 706 or 708 is to be converted to a mirrored VARIANT 70X, then the mounting direction of the **drive unit (26-1)** needs to be changed.

1. Loosen the fastening screws and remove the cover plate.

Fastening screw M3x6

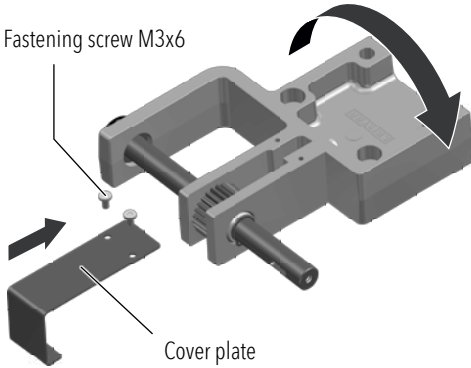

2. Turn the drive unit and refit the cover plate with the fastening screws.

5.15 Floating nozzle

If the welding nozzle is not supposed to rest on the base material, it can be raised. To do so, loosen the lock nut and screw in the adjustment screw until the welding nozzle is at the correct height. Then retighten the lock nut.

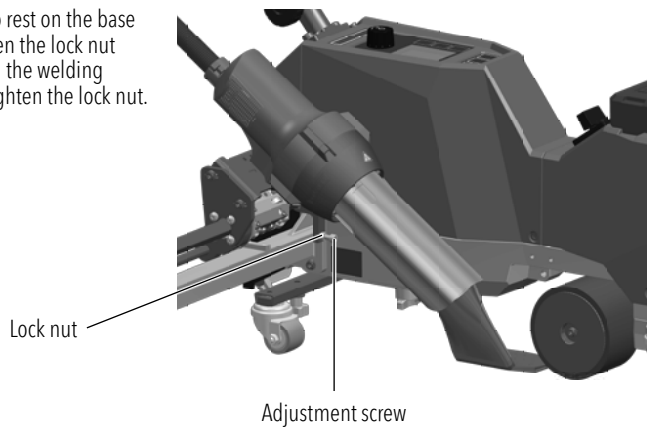

6. VARIANT 70X commissioning

6.1 Work environment and safety

Safety precautions



Risk of death from electric shock due to dangerous electrical voltage

- The device is only to be connected to sockets and extension cables with a protective earth conductor.
- Protect the device from moisture and wet conditions.
- When used on a construction site, a residual current circuit breaker is mandatory.
- Prior to using the device for the first time, check the power cord, the plug, and the extension cable for electrical and mechanical damage.
- The device may only be opened by instructed, qualified personnel.



Danger of fire and explosion with improper use in the vicinity of flammable materials and explosive gases.

- Avoid overheating of the material.
- Never place the device near combustible materials and/or explosive gases.
- Never place the device close to combustible materials and/or explosive gases while it is running and/or hot.
- Only use the device on fireproof surfaces.



Risk of burns due to hot equipment parts and hot air jet

- Do not touch the heating tube and nozzle when they are hot.
- Always allow the device to cool down first.
- Never point the hot air flow at people or animals.



Risk of inadvertently becoming caught and being pulled in due to moving parts

- Do not touch any moving parts.
- Do not wear loose articles of clothing such as scarves or shawls.
- Tie up long hair and protect it with a head covering.



Risk of crushing: There is a risk of crushing due to the movement of mechanical parts.



Health risk due to harmful fumes

- Welding PVC materials creates harmful hydrogen chloride vapors.
- Always ensure good ventilation of the workplace when working.
- Read the material safety data sheet from the manufacturer of the material and follow that company's instructions.
- Be careful not to burn the material during the welding process.



Risk of tripping due to power cord

- The **power cord (8)** must be able to move freely and must not hinder the user or third parties during work (trip hazard).
- The work area must be free from third-party objects.



Risk of excessive physical strain when carrying and lifting the device

- Your VARIANT 70X including transport box weighs approximately 29–36 kg (approximately 24–31 kg without transport box and weight).
- **Two persons** are required to transport the machine with the transport box.
- Comply with applicable national regulations regarding the carrying or lifting of loads.



- The local supply **voltage** must match the nominal **voltage** specified on the device.
- Maximum network impedance according to EN 61000-3-11 / UL 499 / CSA C22.2 No 88: $Z_{max} = 0.169 \Omega + j 0.106 \Omega$. In case of doubt, the responsible electricity supply company should be contacted.



Danger due to uncontrolled restart

- If the power supply fails, switch off the device at the main switch and swivel the hot air blower to the park position (risk of fire, falling and damage). When the appliance is switched on again, it automatically goes into cool-down mode.



Caution

- Comply with national statutory requirements regarding occupational safety (securing personnel or devices).



Caution

- Only use the device on horizontal and fireproof surfaces.

Power supply and extension cable



- The extension cables must be authorized for the utilization site (such as, outdoors) and be marked accordingly. Take into account the necessary minimum conductor cross-section for extension cables, as required.

On-site generators for power supply

When using power generators, they must be grounded and equipped with residual current circuit breakers.

For the nominal output of the power plants, the formula “1.5–2 × nominal output of the hot air welder” applies.

6.2 Operating readiness

Hang the strain relief of the **power supply cord (8)** from the power supply cord **holder (7)** and then check the basic setting of the **welding nozzle (13)**.

See the how-to videos on [Leister's YouTube channel](#)

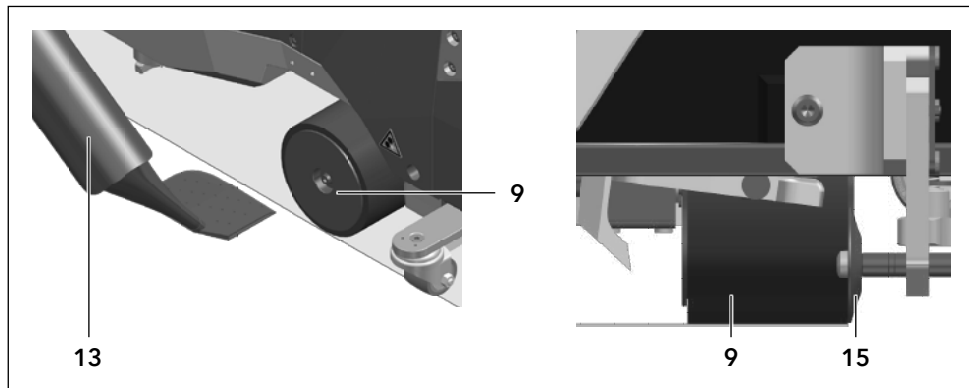

6.3 Starting the device

- Prepare the working area and the hot air welder in accordance with the instructions, then connect the hot air welder to the supply voltage.
- Use the **main switch (18)** to switch the hot air welder on.



If the device was allowed to cool down beforehand, this will be followed by a static display of the set values of the most recently used profile (the Basic profile is displayed when the device is first commissioned).

The heating is not yet switched on at this stage.

- Select the appropriate welding profile or define the welding parameters individually.
- Ensure that the **hot air blower (12)** is swiveled out.
- Use the *Heating* button (38) to switch off the heating.

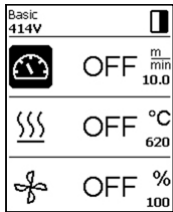

6.4 Welding sequence

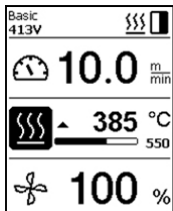

Preparing for welding

As soon as the heating is switched on, a **dynamic display of the current air temperature appears with a progress bar** (actual and set values).

- Make sure that the welding temperature is reached before starting work (the heating-up time is 3–5 minutes).
- First perform test welds in accordance with the material manufacturer's welding instructions and/or national standards or guidelines and check the results. Adjust the welding profile as required.

Start welding

- Move the welding machine to the appropriate position and lower the machine by pressing the *Function I* button (34).
- Lift the tarpaulin material by pressing the *Function II* button (35) (overlap version) or fold back the upper tarpaulin to create space for the welding nozzle.
- Swivel in the welding nozzle by pressing the *Function III* button (36).
- The drive motor starts automatically as soon as the **hot air blower (12)** is swung in.
- The drive can be started manually at any time by pressing the *Drive* button (37).
- Guide the hot air welder by the **guide bar (22)** along the overlap, always paying attention to the position of the **track guide roller (15)**.

Do not exert any pressure on the **guide rod (22)** during the welding process, as this can lead to a reduction in the welding pressure.

NOTE: The *Function I-III (34-36)* button can be configured individually. See chapter Device Settings [9.7].

Finishing welding

- After welding, swivel out the **hot air blower (12)** by pressing the *Function III* button (36) (drive motor stops).
- Then swivel the **track guide roller (16)** upwards.

6.5 Switching off the device/Maintenance

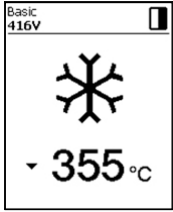

Use the *heating (38)* button to switch off the heating so that the **welding nozzle (13)** cools down.

This triggers the cool-down mode.

- The blower switches off automatically after approx. 5–8 minutes.
- Then switch off the device with the **main switch (18)** and disconnect the **power cord (8)** from the electrical network.



- Wait until the device has cooled down!
- Check the **power cord (8)** and plug for electrical and/or mechanical damage.
- Use a wire brush to clean the **welding nozzle (13)**.

7. VARIANT 70X quick guide



Observe the safety instructions and warnings in the other sections of these operating instructions.

7.1 Switching on/Starting

1. Make sure that the **main switch (18)** is switched off and the **hot air blowers (12)** are in parking position. Connect the supply voltage plug.
2. Switch on the **main switch (18)**.
3. Switch on the heating with the *Heating* button (37); wait 3–5 minutes until the desired temperature is reached.
4. Position the hot air welder and lower it by pressing the *Function I* button (34).
5. Lift the tarpaulin material with the material lift-off device by pressing the *Function II* button (35).
6. Swivel in the **hot air blower (12)** by pressing the *Function III* button (36); the appliance starts automatically.

7.2 Stop/switch off

1. Swivel out the **hot air blower (12)** by pressing the *Function III* button (36); the appliance stops automatically.
2. Switch off the heating with the *Heating On/Off* button (38) and wait for the cooling process to finish (approx. 5–8 minutes).
3. Switch off the **main switch (18)**.
4. Disconnect the **power cord (8)** from the power supply.

VARIANT 700/702/704/706/708
Quick Guide

Operating Instructions:
leister.link/qq-variant-700

Download
myLeister App

1 	2 	3 	4
 230V / 400V			 5min

1 	2 	3 	4

QG VARIANT 700/702/704/706/708 / 09.2024 / 171.257

8. VARIANT 70X operating unit



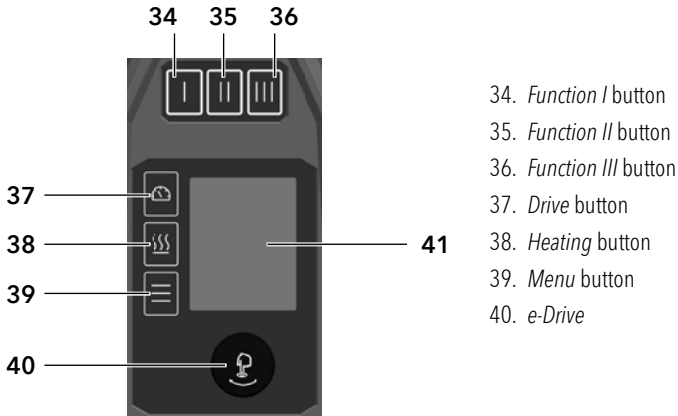

The **control panel (1)** is comprised of the **function buttons** with which you control the various menu functions, and the **display** where the respectively selected setting, menu options or the values valid for the running time are displayed.

8.1 Function buttons



Multiple allocation of function buttons Control panel (1)

Symbol	Name	In the work display (43)	In the menu, after pressing the button (39)
	Function I button (34)	Std: Lifting/lowering the machine	
	Function II button (35)	Std: Swiveling the material lift-off in/out	
	Function III button (36)	Std: all-in-one -> lower machine, lift the material, swivel in the heating air fan or swivel out the heating air fan, lift machine	
	Drive button (37)	Switch the drive on/off	Selection of line when editing text

	Heating button (38)	Switching heating on and off	Selection of line when editing text
	Menu button (39)	Switch to menu	return to the working display
	e-Drive (40) press	Selected value is adopted, selection goes straight back to the function display	Selects the marked position
	e-Drive (40) rotate	Sets the required setpoint in 0.1m/min, 10°C or 5% steps	Changes the position within the setup menu and sets the value of the selected position

8.2 Display

The **display (41)** is subdivided into two display areas:

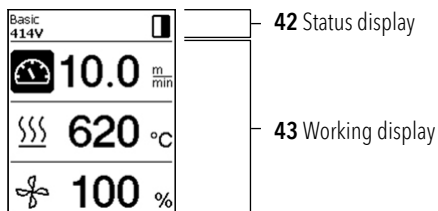

8.3 Setting the welding parameters

To adjust a welding parameter before welding, proceed as follows:

Example for setting the welding temperature

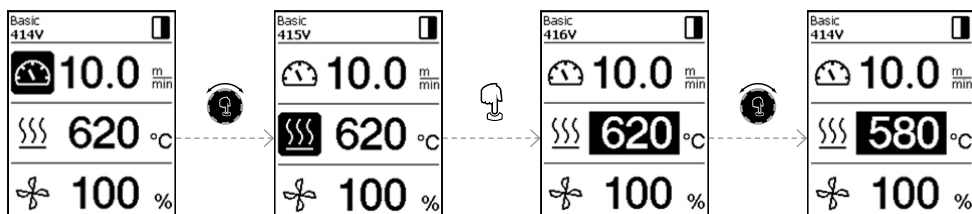

If you do not make any more entries, the cursor automatically jumps back to the temperature symbol. You can then select the next welding parameter with the *e-Drive* button (40).

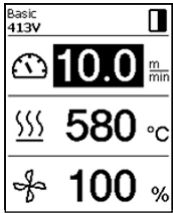

During the welding process, the cursor is always on the Drive icon. **You can adjust the welding speed at any time using the e-Drive button (40).**

If you want to adjust another parameter, first press the e-Drive button (40), then turn the e-Drive button (40) and select the desired parameter.

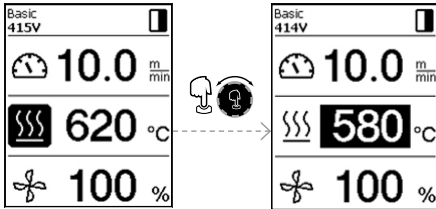

If you do not make any further entries, the cursor automatically jumps back to the Drive icon if the Info Mode is not switched on.

8.4 Display symbols of the status display (Display 40)

The status display (42) on the **display (41)** is subdivided into a left-hand (1) and a right-hand area (2).

Status display 1/Left	
Profile name	Displays the name of the selected, currently valid welding profile (such as Basic). If a profile name contains more than 6 characters, the first 6 characters are shown first, followed by the remaining 6 characters. The system then presents the first 6 characters.
Voltage	Display of the supply voltage
Status display 2/Right	
Heating	Heating on/off display
Aggregate	Display of the connected blowers, black means connected



Warning present



Heating



Overvoltage



Eco-Mode











Undervoltage

8.5 Display symbols of the work display (Display 41)

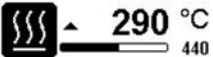
	9.5 $\frac{\text{m}}{\text{min}}$
	620 °C
	100 %

During operation, the set values of the welding parameters (drive in m/min or ft/min, temperature in degrees Celsius (°C) or Fahrenheit (°F), air volume in percent (%) and, if applicable, information notes (see  General Info [9.10]) are displayed.

You can use the *e-Drive* button (40) to switch between the welding parameters. By pressing the *e-Drive* button (40), you select the respective parameter and then adjust it individually by turning the *e-Drive* button (40).

	Symbol drive/welding speed [m/min or ft/min]
	Symbol air temperature [°C or °F]
	Symbol air volume [%]
	Welding temperature too low, heating process up arrow and progress bar show that the desired higher temperature has not yet been achieved. The flashing number above the progress bar designates the currently achieved actual value (290); the value near the right of the bar (460) shows the set value of the selected welding profile or of the individual setting.
	Welding temperature too high, cooling process down arrow and progress bar show that the desired lower temperature has not yet been achieved. The flashing value above the bar designates the currently achieved actual value (535); the value near the right of the bar (430) shows the set value of the selected welding profile or of the individual setting.
	Symbol for cool-down mode
	Symbol for hardware error warning The device is no longer ready for operation. Please contact your authorized Leister sales and service partner. Note the respective error code in Section Warning and Error Messages.
	Symbol for hardware error warning (heating element is defective). The device is no longer ready for operation. Please contact your authorized Leister sales and service partner.
	Symbol for excessive temperature warning . Allow the device to cool down.

9. Settings and functions of the VARIANT 70X software

9.1 VARIANT 70X menu navigation overview

Note: Pressing the *Menu* button (39)  will return you to the working display in each menu item.

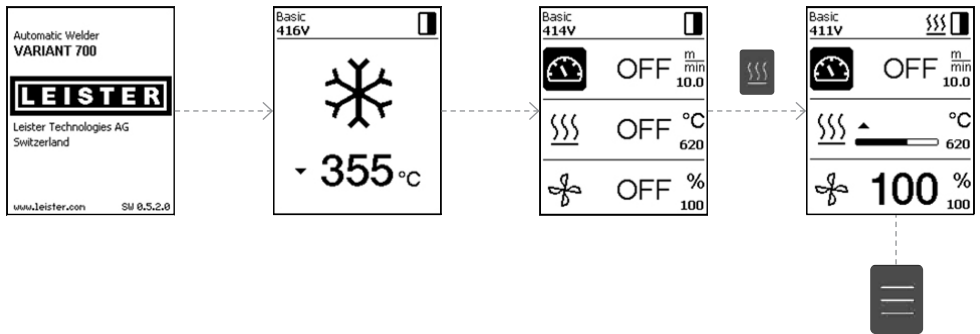

Example: Selection of recipes

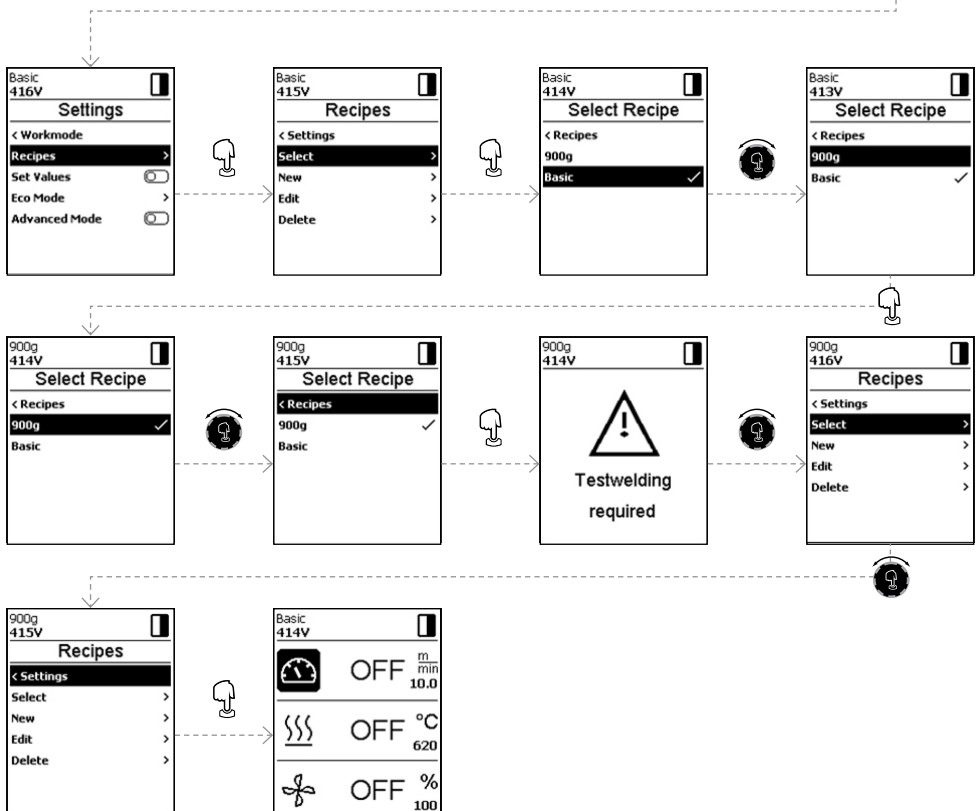

9.2 Basic setting

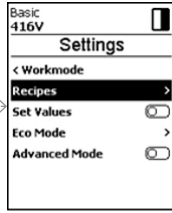

- Formulas
- Display of set values
- Eco-Mode
- Advanced mode

9.3 Formulas

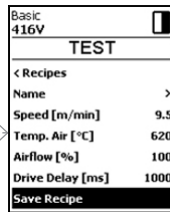
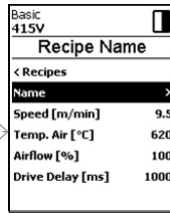
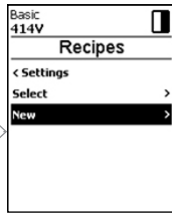
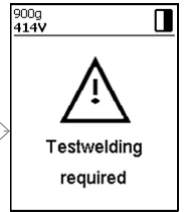
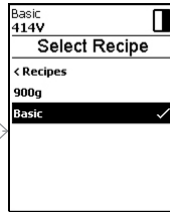
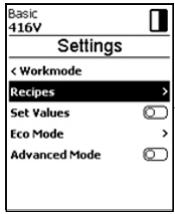

To change the parameters of the customizable recipes, proceed as follows:

Note: All customizable recipes are displayed.

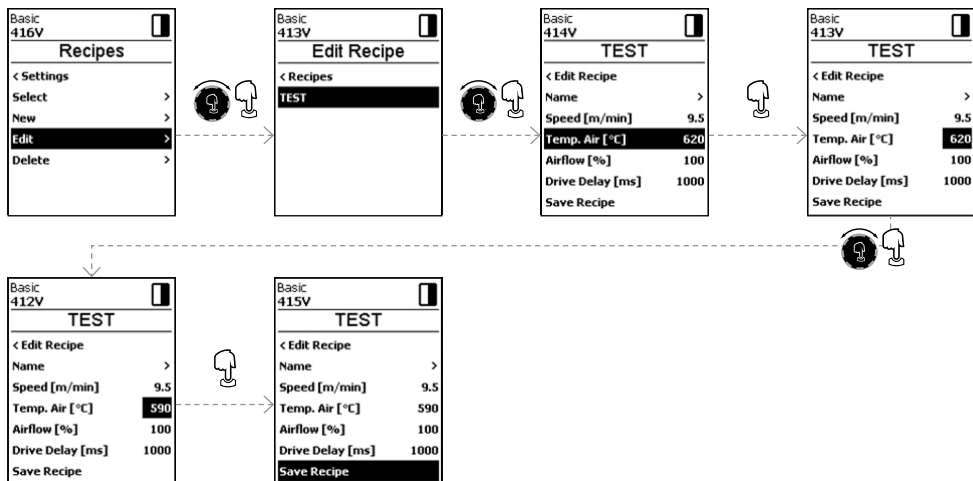

9.4 Displaying set values

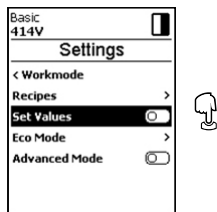

The actual value and set value display is switched on in the working display (43) at the factory.

If no actual and set values are to be displayed in the working display (43), the Set Values can be deactivated.

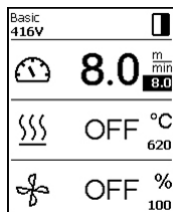

Set Values on

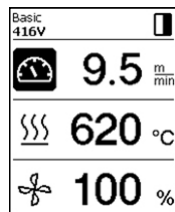

Set Values off

If the Set Values function is activated, the actual temperature (high) and the target temperature (low) are shown in the work display (43).

This applies analogously for drive (m/min) or air volume (percent).

9.5 Eco-Mode

The Eco-Mode function is switched off at the factory. You can activate Eco-Mode by pressing the *e-Drive* button (40).

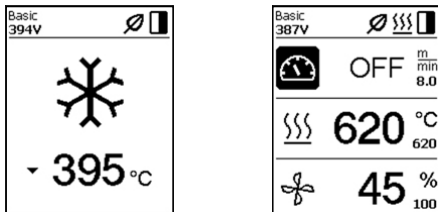
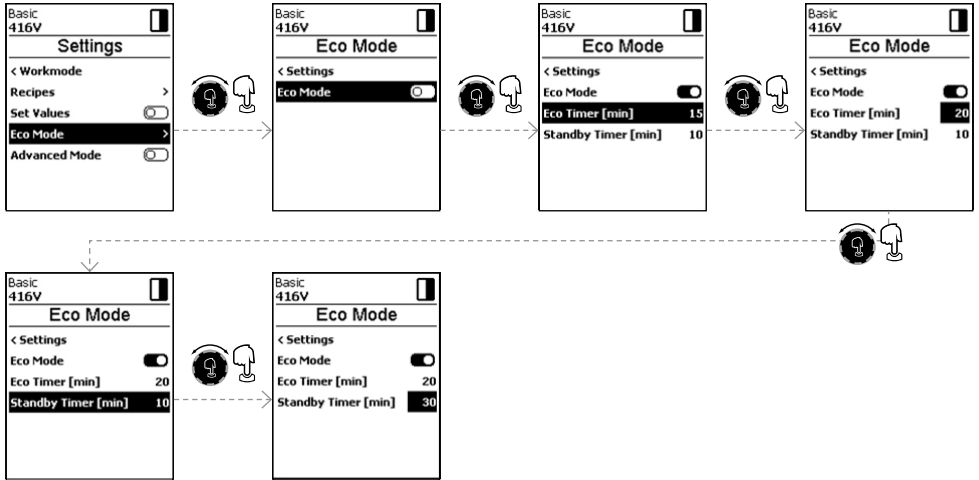

If Eco-Mode is activated and the device remains inactive (no buttons pressed for the set period of time), you will automatically switch to Eco Timer mode. The air volume is automatically reduced to 45%. In the working display (43), the Eco Timer is displayed with the corresponding symbol.

After the Standby Timer has expired without activity, the cooling process is automatically initiated. The cooling process can be interrupted with the *heating* button (38).

9.6 Advanced mode settings

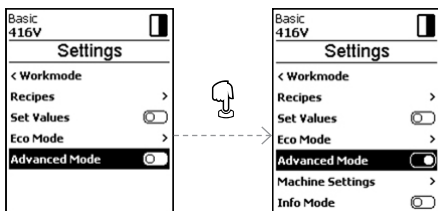

If you have activated Advanced Mode, additional menu options are available to you.

9.7 Device settings



Date & Time

Setting the hour, minute, year, month and day.

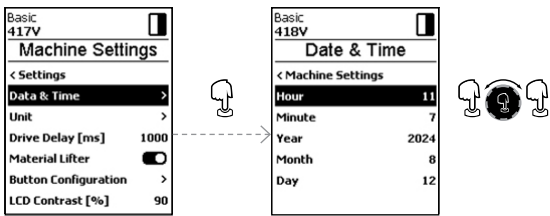

Unit

Selection of the display units; metric or imperial.

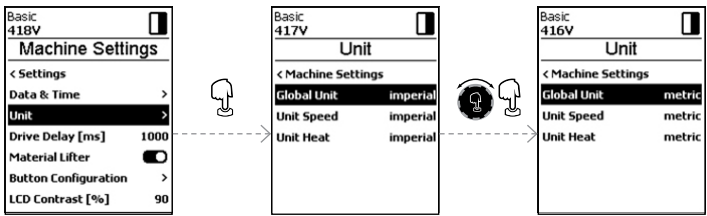

Drive delay

Setting the start-up delay: 0 ms means that the drive starts when the swiveling-in process has been triggered.

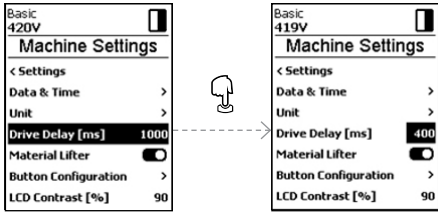

Material Lifter

Activation or deactivation of the tarpaulin lift.

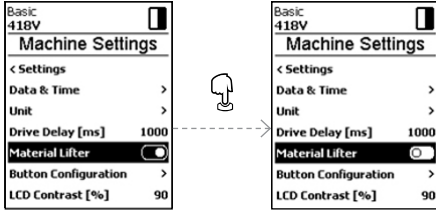

Button Configuration

Configuration of the function buttons.

The default factory configuration is as follows:

Function I button (34): Lowering and lifting the machine

Function II button (35): Material lifting

Function III button (36): All in one (swiveling in and out of the nozzle and all actions not yet performed)

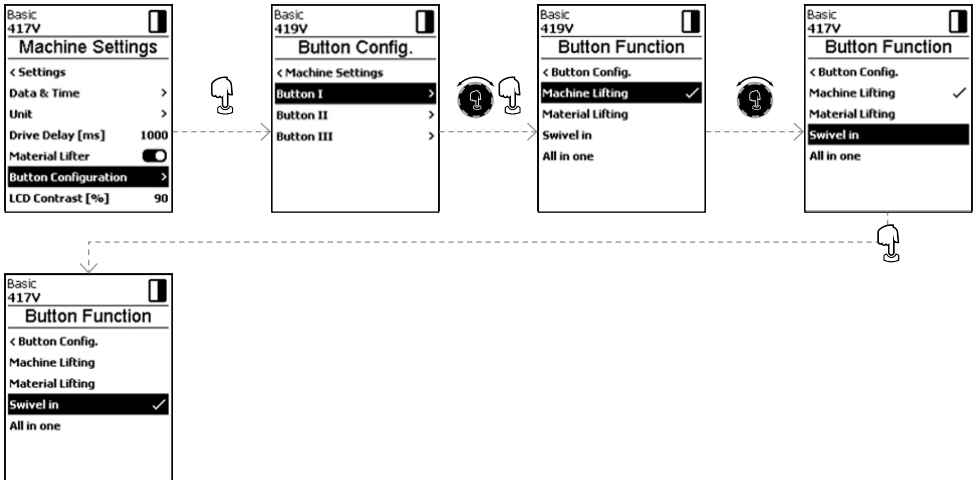

With the All-in-one function, all non-executed functions are executed one after the other.

LCD Contrast

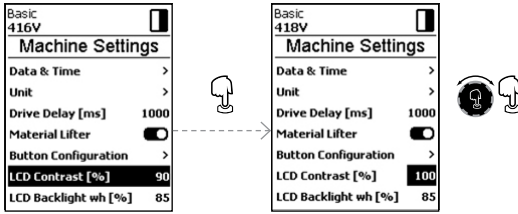

LCD Backlight (wh, rd)

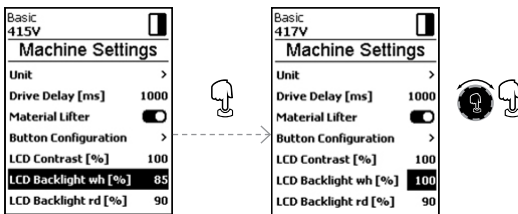

Backlight button

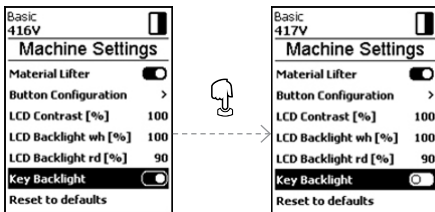

Using the Key Backlight function you can switch the illumination of the keyboard on or off.

Reset to defaults

Activating the Reset to defaults function resets all settings to factory default.

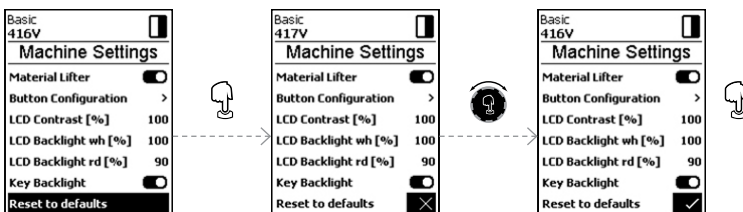

9.8 Info mode

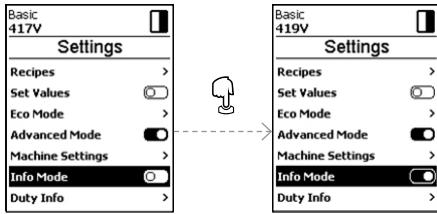

Info Mode is switched off at the factory.

If Info Mode is activated, additional information is displayed at the work level.

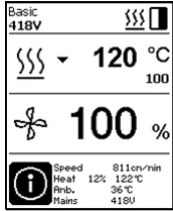

The following information is displayed:

- Speed in cm/min
- Capacity utilization of the heating output in percent as well as the temperature in °C
- Ambient temperature in °C
- Mains voltage in V

9.9 Duty info

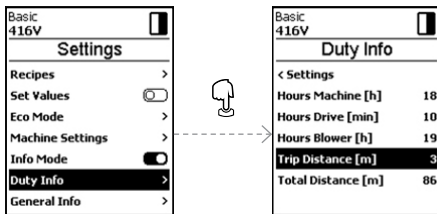

Under Duty Info, the runtimes of the machine, the drive and the blower are displayed. In the two lines below, the distances traveled as a day counter and as total run time are visible. The day counter can be reset.

To delete the day counter, select the menu item Trip Distance.

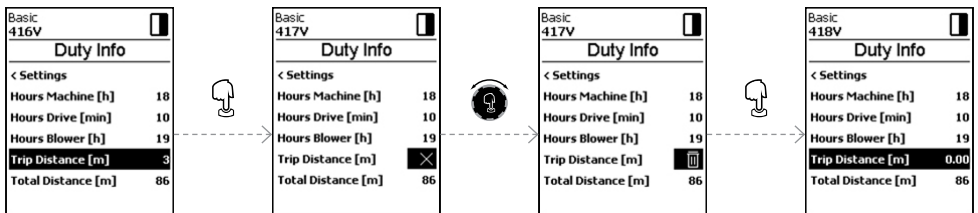

9.10 General Info

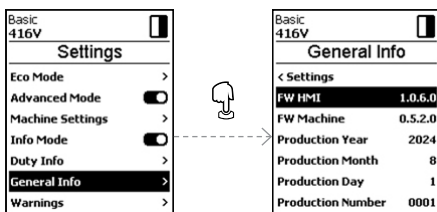

The following information is displayed:

- Software version HMI and PCU
- Production date of the machine
- Serial number

10. VARIANT 70X warning and error messages

All warnings are displayed via the Warnings function.

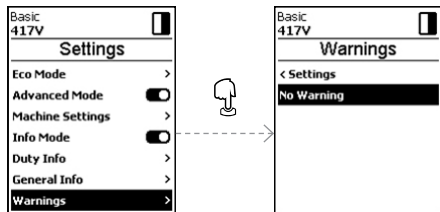



If there is a warning pending, you can still continue to work largely without restrictions.

In contrast to the warning message, it is **not possible to continue working once an error message has appeared**. The heating is switched off automatically and the drive is blocked. The display of the corresponding error codes takes proceeds without delay in the Work display (43).

You can receive specific information regarding the type of error or warning at any time, including via the menu Settings under Show Warnings.

Message type	Display	Error code	Description and measures
Warning		---	<ul style="list-style-type: none"> Example warning symbol in the status display (33). Supply voltage too high. At the same time, the red backlight of the LCD module is switched on alternately.
Error		0020	<ul style="list-style-type: none"> Error symbol and text of note (Error No. 0020/Heating element defective) in the work display. Solution: Replace the heating element

Continue to next page

Error (including address of sales and service partner, if applicable)*	<div style="border: 1px solid black; padding: 5px;"> <p>Basic 162V</p>   <p>Error No.0002</p> </div>	0002	Undervoltage/overvoltage
		0004	Hardware error
		0008	Thermoelement is defective
		0100	Blower is faulty
		0200	Communication module error
	0400	Drive error	
<div style="border: 1px solid black; padding: 5px;"> <p>Basic 232V</p>  <p>Error No.0100 Contact your service center</p> <p>www.leister.com</p> </div>			
Contact *Leister Sales and Service Partners			

11. VARIANT 70X FAQs, causes and measures



The device switches on automatically after the blowers have been switched on:

- If the temperature is higher than 100°C when the device is switched on – which can occur, for example, if the device is disconnected from the power supply without the cooling process – the device automatically switches to cool-down mode. The cooling process ends when the temperature has been below 50°C for two minutes.

Unit switches off automatically:

- In Standby operation, the heating is switched off automatically after the time elapses that the user has stored (see also  Standby/Eco Mode [9.5]).

Welding result of deficient quality:

- Check drive speed, welding temperature and air volume.
- Clean **welding nozzle (13)** with wire brush (see  Switch off device/maintenance [6.5]).
- **Welding nozzle (13)** set incorrectly (see  Setting the welding nozzles [5.1])
- **Incorrect device operation**, contactsalessupport@leister.com

If the set welding temperature still has not been reached after 5 minutes:

- Check the supply voltage
- Reduce the air volume
- Check heating element

12. Accessories

For more information please visit leister.com.

13. Service and repair

Repairs shall be performed exclusively by authorized Leister sales and service partners. You will find the address of your authorized Leister sales and service partner on the last page of these operating instructions.

For more information please visit leister.com.

14. Training

The Leister Academy and its authorised Leister sales and service partners offer welding courses as well as product and application training.

For more information please visit leister.com.

15. Declaration of Conformity

EU Declaration of Conformity

Leister Technologies AG, Galileo-Strasse 10, 6056 Kaegiswil, Switzerland confirms that this product fulfills the requirements of the following EU Guidelines in the models that we have made available for purchase.

Directives: 2006/42/EC, 2014/30/EU, 2011/65/EU

Harmonized standards: EN ISO 12100, EN 60335-1, EN 60335-2-45, EN 62233, EN 55014-1, EN 55014-2, EN 61000-3-2, EN 61000-3-3, EN 61000-6-2, EN IEC 63000

Name of authorized representative for documentation: Thomas Schäfer, Manager Product Conformity

Kaegiswil, 11/11/2024

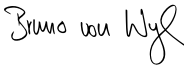

Bruno von Wyl, CTO



Pascal Bösch, VP R&D

16. Disposal



Do not dispose of electrical equipment with household refuse!

Electrical equipment, accessories and packaging should be recycled in an environmentally friendly manner. When you are disposing of our products, please observe the national and local regulations.

Warranty

- The guarantee or warranty rights granted for this device by the direct distribution partner/salesperson apply from the date of purchase. In the event of a guarantee or warranty claim (verification by invoice or delivery note), manufacturing or processing errors will be rectified by the sales partner through replacement delivery or repair. Heating elements are excluded from warranty obligations or guarantees.
- Other guarantee or warranty claims are excluded within the framework of mandatory law.
- Damage resulting from natural wear, overload, or improper handling is excluded from the warranty.
- Devices that have been converted or modified by the purchaser are not covered by any warranty or guarantee.
- Only use original Leister spare parts and accessories; otherwise, any warranty or guarantee claims will be invalidated.

↳ Sales and Service Partners



Leister Technologies AG

Galileo-Strasse 10

6056 Kaegiswil

Switzerland

+41 41 662 74 74

leister@leister.com

leister.com