



**HEMTEK
ST**

**HEMTEK
K-ST**

English



Leister Technologies AG

Hilltop Products Ltd

www.hilltop-products.co.uk

Tel: +44 1942 723101

Email: sales@hilltop-products.co.uk

Contents

1. Important Safety Instructions	3
1.1 Intended Use	4
1.2 Improper Use	4
2. Technical Data	5
3. Transport	5
4. Your HEMTEK ST / K-ST	6
4.1 Type Plate and Identification	6
4.2 Scope of delivery (standard equipment)	6
4.3 Overview of device parts	7
5. Settings on the HEMTEK ST / K-ST	9
5.1 Setting and assembling table fastening	9
5.2 Adjusting the guide	10
5.3 Insulation silicone plugs (only HEMTEK ST)	10
5.4 Adjusting the contact pressure weight	11
5.5 Welding nozzle	11
6. Commissioning your HEMTEK ST / K-ST	13
6.1 Work environment and safety	13
6.2 Operating readiness	13
6.3 Positioning	13
6.4 Starting the device	14
6.5 Welding Sequence	14
6.6 Finishing welding	15
6.7 Switching off the device / Maintenance	15
7. Quick Reference Guide HEMTEK ST / K-ST	16
8. Warning messages (HEMTEK ST / K-ST)	16
9. FAQs, causes and measures (HEMTEK ST / K-ST)	17
10. Accessories	17
11. Service and Repair	17
12. Training Course	17
13. Declaration of Conformity	18
14. Disposal	18

Operating instructions (translation of operating instructions)

We congratulate you on your purchase of a HEMTEK ST / K-ST!

You have chosen a first-class hot air welder.

It was developed and produced in accordance with the very latest state of technology in the plastics-processing industry. The device has been manufactured using premium-quality materials.



Read through the operating instructions before commissioning.

Always store these operating instructions at the device.

Do not pass the device on to other personnel without the operating instructions.

HEMTEK ST / K-ST Automatic welder



1. Important Safety Instructions

In addition to the safety instructions contained in the individual chapters of these operating instructions, the following provisions are also to be followed strictly at all times.



Warning



Danger to life! Before opening the device, pull the mains plug out of the socket, because voltage-bearing components and connections will be exposed when it is opened!



Danger of fire and explosion exists in connection with improper use of the automatic welder (e.g., due to material overheating) and particularly in the vicinity of flammable materials and explosive gases.



Risk of burning!

Do not touch heating element, nozzle and components in the immediate vicinity of the nozzle when hot. The device should always first be allowed to cool down. Do not point the hot air flow at people or animals!



Connect the device to a **socket with a protective conductor**. Any interruption of the protective conductor inside or outside of the device is dangerous. Use extension cables with protective conductors exclusively!



Risk of clamping injuries!

A danger of clamping injuries exists with the tilting mechanism when the hot-air blowers swivel in and out.



Risk of entanglement!

During operation there is a risk of entanglement on the drive roller.



Caution



The **nominal voltage** specified on the device must match the local **supply voltage**. If the network voltage fails, then the main switch and the drive must be switched off (raise the drive roller).



The device **must be monitored continuously during operation**. Waste heat can come into contact with flammable materials that are not in view.

Device may be operated only by **trained specialists** or under their supervision. Children are not permitted to operate the equipment under any circumstances.



Caution



Protect the device **from moisture and wet conditions**.



For transporting the hot air welder **two people** are needed.



When working on the open system, do **not wear clothing such as scarves, shawls, or neckties**. **Tie up long hair** or protect it by wearing headgear.

1.1 Intended Use

The HEMTEK ST / K-ST is designed for professional indoor utilization for welding tarpaulins.

Use only original Leister spare parts and accessories because otherwise no warranty or guarantee claims can be asserted.

HEMTEK ST welding processes and material types:

- Hem, hemstitch and fillet welds of thermoplastic materials
- Welding widths 20, 30, 40 mm

HEMTEK K-ST welding processes and material types:

- Flap-piping-welding of thermoplastic materials
- Welding width 8 mm

1.2 Improper Use

Any other use or any use beyond that described is deemed as improper use.

2. Technical Data

		HEMTEK ST 120 V		HEMTEK ST 230 V		HEMTEK K-ST 120 V	HEMTEK K-ST 230 V
Nozzle width	mm	20/30/40	30/40	20		8	8
Nominal voltage	V~	120	220–240	220–240		120	220–240
Nominal voltage	W	1 800	3 450	2 350		1 800	2 350
Frequency	Hz	50 / 60				50 / 60	
Temperature, stepless	°C	100–650				100–650	
Air volume, stepless		1–10				10	
Drive, stepless	m/min.	0,8–12				0,8–12	
Emission level	L _{pA} (dB)	70 (K = 3 dB)				70 (K = 3 dB)	
Dimensions (L × W × H)	mm	433 × 350 × 600				433 × 350 × 600	
Weight	kg	27 (including table fastening)				27 (including table fastening)	
Mark of conformity		CE	CE	CE		CE	CE
Protection Class I		⊕	⊕	⊕		⊕	⊕

Subject to change without prior notice.

3. Transport



Comply with applicable national statutes regarding the carrying or lifting of loads.
The weight of your HEMTEK ST / K-ST excluding table fastening is 20 kg.

Two persons are required for transportation with the table fastening.



The **hot-air blowers (1)** MUST be allowed to cool down prior to transport.



Never use the **carrying handle (2)** on the device for transporting with a crane.



Never use the **hot-air blowers (1)** to lift the hot-air welding machine.

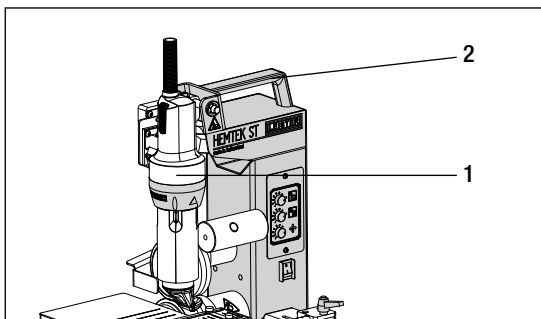

To lift the hot air welder by hand, use the **carrying handle (2)**.

4. Your HEMTEK ST / K-ST

4.1 Type Plate and Identification

The model and serial number are indicated on your device's **type plate (8)**.

Enter this information into your operating instructions and always reference this information when addressing inquiries to our representatives or authorized Leister Service points.

Model:.....

Serial no.:.....

Example:



4.2 Scope of delivery (standard equipment)

HEMTEK ST

1 × HEMTEK ST device

- Table fastening console
- HEM material guidance
- Scraper
- Silicone plugs

1 × Main catalog

1 × Folder

HEMTEK K-ST

1 × HEMTEK K-ST device

- Table fastening console
- Flap-piping guide

1 × Main catalog

1 × Folder

4.3 Overview of device parts

HEMTEK ST

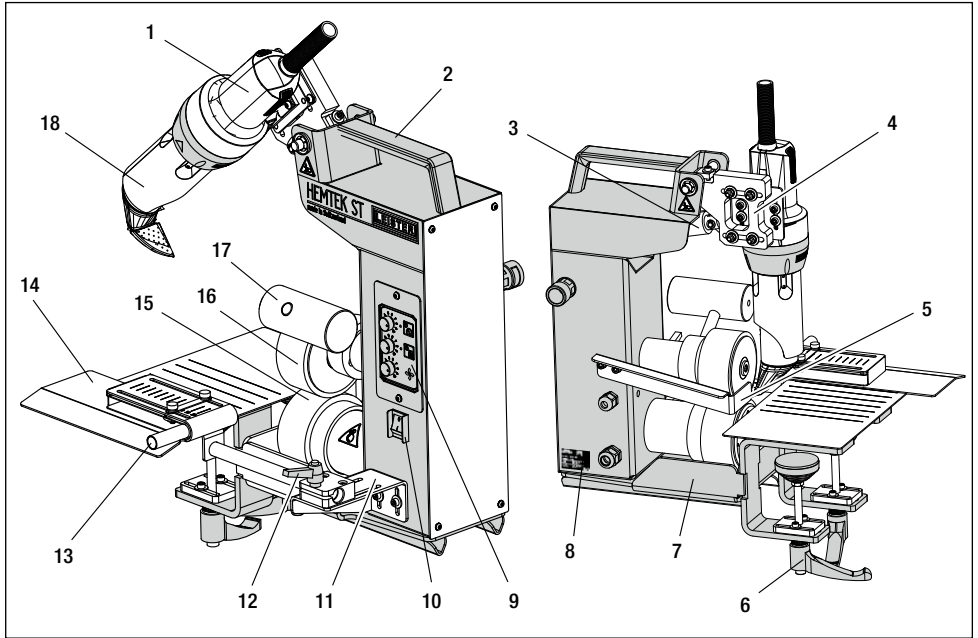

- | | |
|---|--|
| 1. Hot-air blowers | 13. Silicone plugs (remove for piping welding) |
| 2. Carrying handle | 14. Hem, open hem and piping guide |
| 3. Electric lifting cylinder | 15. Drive wheel |
| 4. Fixing unit hot-air blowers | 16. Pressure wheel |
| 5. Scraper | 17. Adjustable weight |
| 6. Clamping lever for table fastening feet | 18. Nozzle |
| 7. Table fastening | 19. Speed potentiometer |
| 8. Type plate with model designation and the series marking | 20. Drive status LED |
| 9. Control panel | 21. Start/stop welding (identical to foot pedal) |
| 10. Main Switch | 22. Potentiometer temperature |
| 11. Fastening console guide | 23. Heating / cooling status LED |
| 12. Clamping lever and fixing unit for guide | 24. Heating on / off |
| | 25. Air volume |

Fig. 1 Control panel (9) ST

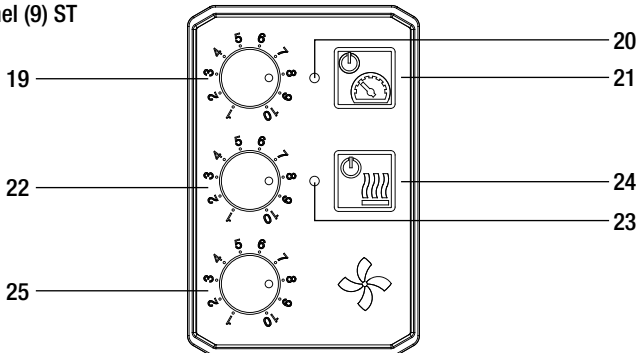

HEMTEK K-ST

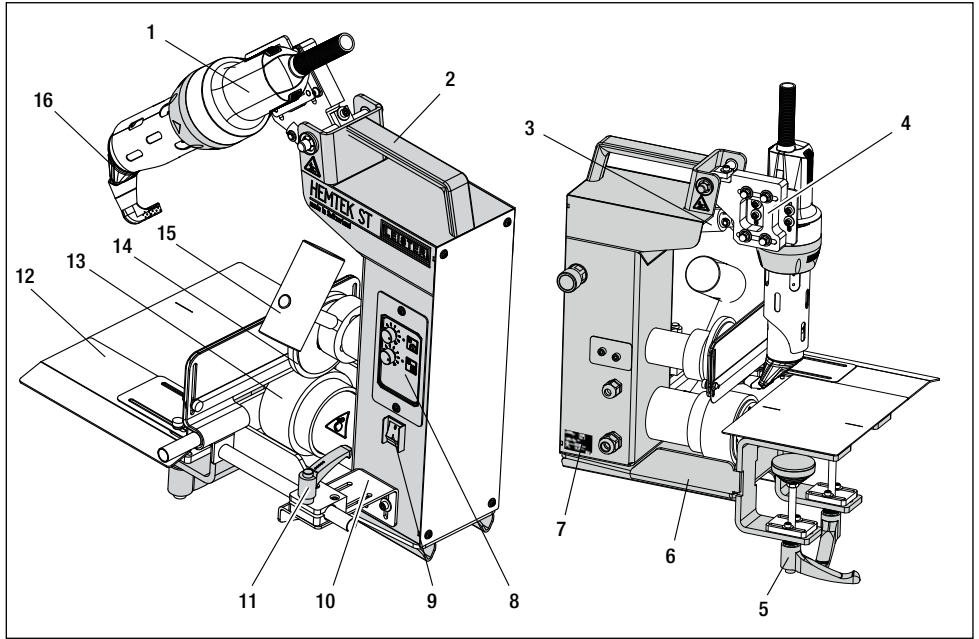

- | | |
|---|--|
| 1. Hot-air blowers | 13. Drive wheel |
| 2. Carrying handle | 14. Pressure wheel |
| 3. Electric lifting cylinder | 15. Adjustable weight |
| 4. Fixing unit hot-air blowers | 16. Flap-piping nozzle |
| 5. Clamping lever for table fastening feet | 17. Speed potentiometer |
| 6. Table fastening | 18. Drive status LED |
| 7. Type plate with model designation and the series marking | 19. Start/stop welding (identical to foot pedal) |
| 8. Control panel | 20. Potentiometer temperature |
| 9. Main Switch | 21. Heating / cooling status LED |
| 10. Fastening console guide | 22. Heating on / off |
| 11. Clamping lever and fixing unit for guide | |
| 12. Double flap-piping guide | |

Fig. 1 Control panel (9) K-ST

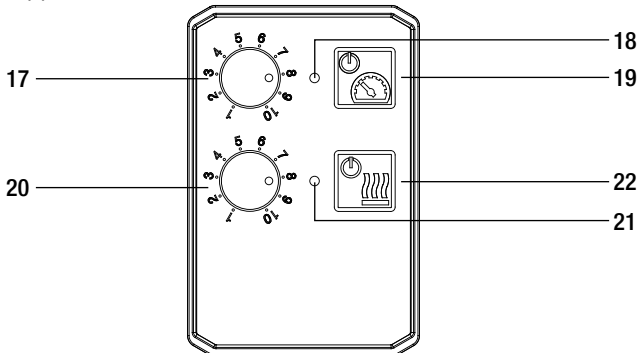

5. Settings on the HEMTEK ST / K-ST

5.1 Setting and assembling table fastening



Use only stable tables or workbenches that can support the load without tipping over.



Two persons are required to transport the welder.

Set table fastening

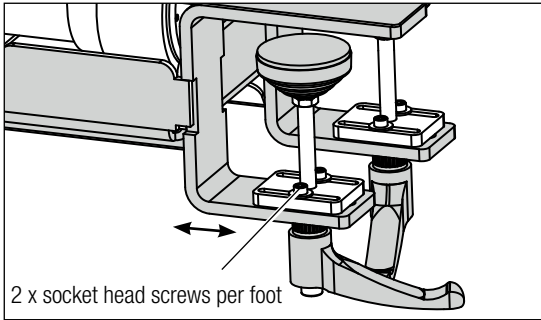

Clamping feet can be adjusted to the different tables using the two socket head screws.

Mount HEMTEK ST / K-ST on table fastening

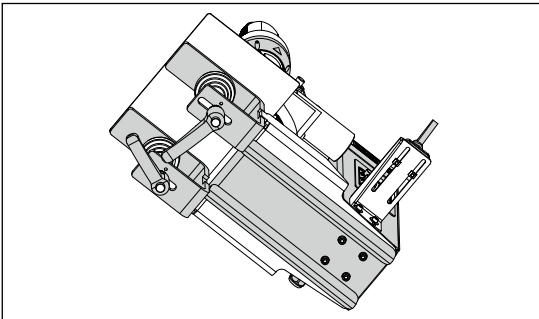

- Mount table fastening on table using enclosed socket head bolts (Check stability.)
- Position HEMTEK ST / K-ST on table fastening. Make sure that the machine is mounted parallelly to table fastening.
- Tighten the HEMTEK ST / K-ST using the 4 socket head bolts
- Check correct seating and stability of the welder.

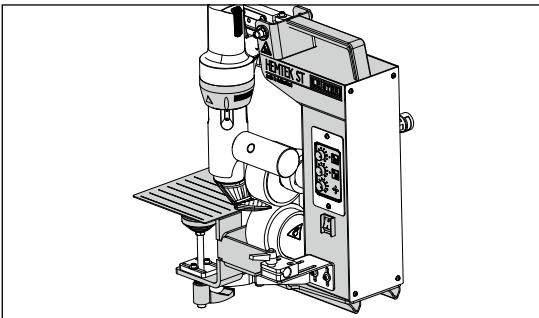

5.2 Adjusting the guide



Risk of burning!

Guide may be hot after prolonged welding. The device should always first be allowed to cool down.

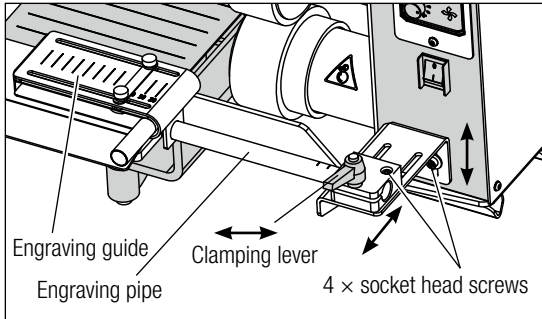

First assemble, detach the clamping lever in counter-clockwise direction and carefully insert the tube. Once the desired position has been reached, tighten the clamping lever in clockwise direction.

The guide exhibits diverse engravings, which serve as an adjustment aid. The recommended basic setting depends on the size of the nozzles.

Setting may vary depending on the material.

- Guide designation 20, 30, 40 or for entirely welded hem.
(Set to 40 mm in diagram)
- Engraving on pipe is from left to right for the basic setting 40, 30, 20 mm nozzle (only completely welded hem).

5.3 Insulation silicone plugs (only HEMTEK ST)

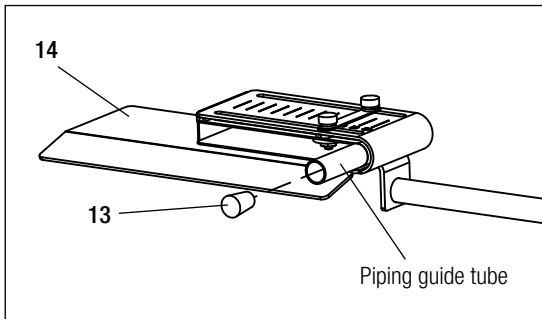

Piping guide tube is only used for welding piping. For hems and open hems, this pipe is sealed using the **silicone plugs (13)**. This plug prevents hot air from being blown through the piping guide tube.

5.4 Adjusting the contact pressure weight

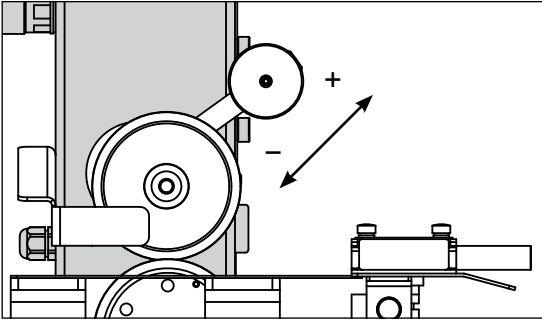

Shifting the weight grip can be used to adjust the effective load of the contact pressure wheel. Shifting the mass downwards reduces the contact pressure, shifting it upwards increases it.

Contact pressure in position shown approx. 150 N.

5.5 Welding nozzle



Risk of burning!

Do not touch heating element tube and nozzle when they are hot. The device should always first be allowed to cool down!

The following is the basic setting of the welding nozzles of your HEMTEK ST

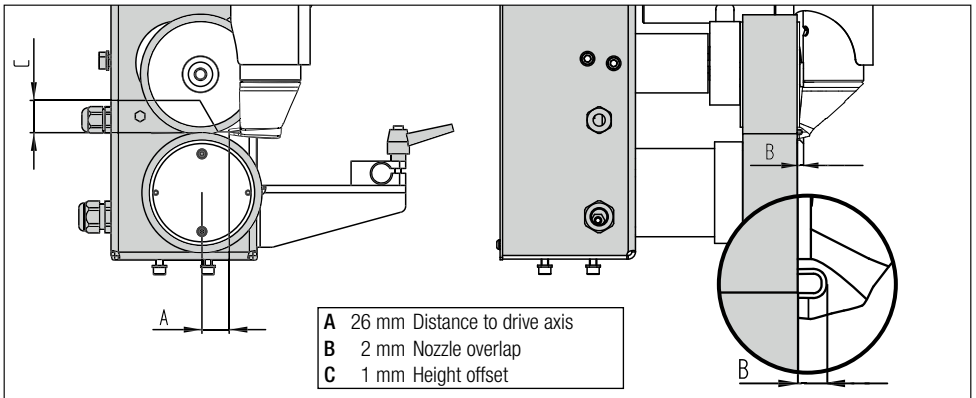

The following is the basic setting of the welding nozzles of your HEMTEK K-ST.

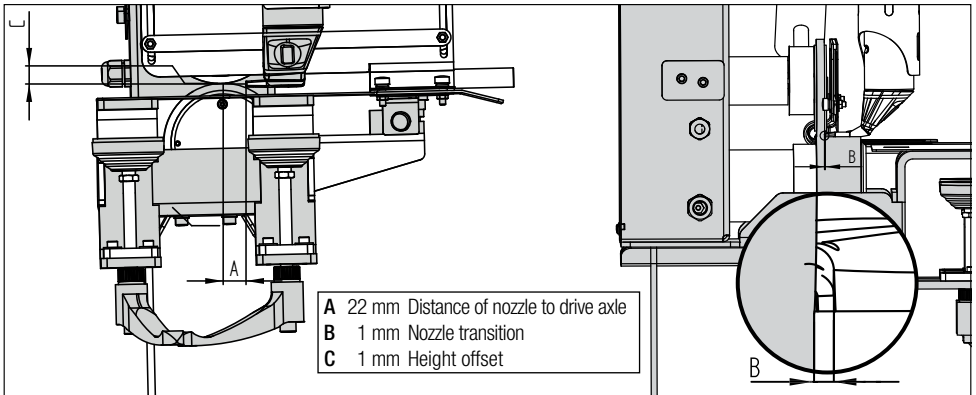

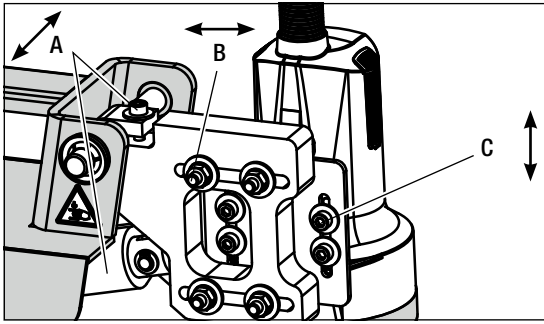

Dimension (A)

Set (1 × socket head screw) and slide at the same time with the linear drive.

Dimension (B)

Set (4 × hexagon nut)

Dimension (C)

Set (4 × socket head screws)

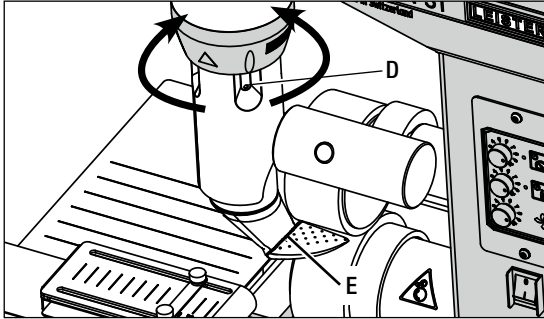

(D)

4 x combination Torx screws

(E)

Parallel drive wheel on nozzle shoe

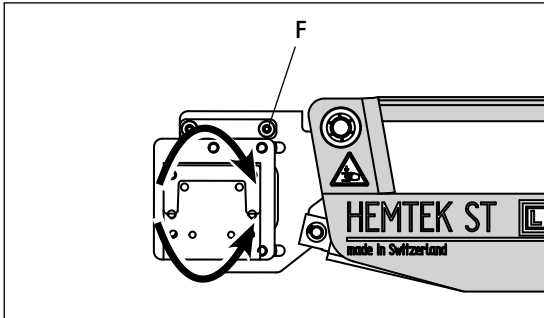

(F)

2 x socket head screws + 4 x hexagon nut
(of dimension B)

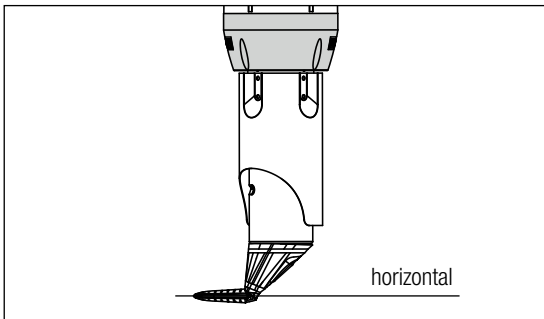

To monitor, extend and retract the nozzle in cold state several times and carry out any necessary fine adjustments if necessary. An adjustment aid is available as an accessory, article no. 157.098

6. Commissioning your HEMTEK ST / K-ST

6.1 Work environment and safety



The hot air welder should be used only in well-ventilated indoor areas.

Never use the hot air welder in explosive or readily inflammable surroundings and maintain sufficient distance from combustible materials or explosive gases at all times.

Read the material safety data sheet of the manufacturer of the material and follow that company's instructions. Be careful not to burn the material during the welding process.

Use only stable tables or workbenches that can support the load without tipping over.

Contact the manufacturer without fail should uncertainties arise during installation or operation.

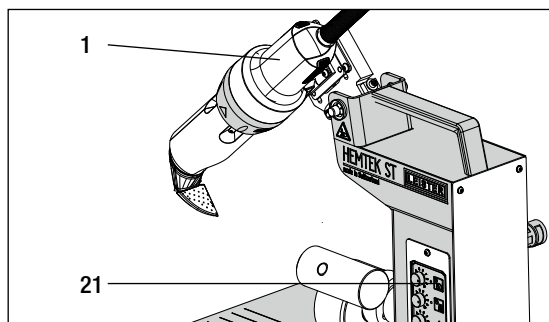

During work interruptions or when cooling down, you must swivel the **hot-air blowers (1)** into park position using the pedal or **pressure buttons (21)**.

Power supply cord and extension cable

The nominal voltage specified on the device (see technical data) must match the mains voltage.

Power plants for energy supply

When using power plants as an energy supply, please ensure that the power plants are grounded and equipped with earth leakage circuit breakers.

For the nominal output of the power plants, the formula $2 \times$ nominal output of the hot air welder applies.

Please note that the automatic welder is only intended to be used indoors. Ensure that all requirements from the instruction manual for the unit are met.

6.2 Operating readiness

Check the setting **guide (14)** and afterwards the basic setting of the **welding nozzle (18)**.

Check the **table fastening (7)** is fastened correctly and that the work table is stable.

6.3 Positioning

- Check whether the material to be welded is clean on the upper and lower sides.
- Afterwards, check whether the **welding nozzle (18)** and the **drive/pressure roller (15/16)** are clean.
- Now feed the material neatly into the **guide (14)** and fold the contact **pressure roller (16)** downwards with the help of the **weight grip (17)**.
- Check whether the material is positioned parallel to the welder and whether the **welding nozzle (18)** is easily retracted.

6.4 Starting the device



Risk of burning!

Do not touch heating element, nozzle and components in the immediate vicinity of the nozzle when hot. The device should always first be allowed to cool down. Do not point the hot air flow at people or animals!

- Once you have prepared the working area and the hot air welder in accordance with the description, connect the hot air welder to the mains voltage.
- Switch the wedge welder on via the **main switch (10)**.
- Define the **welding parameters for drive (19)**, **air temperature (22)** and **air volume (25)** on the respective potentiometer.
- Now switch on the heating [**Direct heating button (24)**].

6.5 Welding Sequence

- Preparing for welding
- Make sure that the welding temperature has been reached before commencing work. The heat-up time is 3 – 5 minutes.
- Now carry out test welds in accordance with the welding instructions of the material manufacturer and/or national standards or regulations and inspect the results. Adjust the welding profile as needed.



Risk of clamping injuries!

A danger of clamping injuries exists with the tilting mechanism when the hot-air blowers swivel in and out.



Risk of entanglement!

During operation there is a risk of entanglement on the drive roller.

Commencing welding

- Actuate the **pressure button (21)** or the foot pedal to start the welding automatically.
- The drive motor starts automatically as soon as the **hot-air blowers (1)** are swiveled in.

Guiding the material during the welding process

- Guide the material with a good tension during the welding process

6.6 Finishing welding

After the welding, actuate the foot pedal or the **pressure switch (21)**, the **motor for generating preheated air (1)** extends and the drive stops automatically.

6.7 Switching off the device / Maintenance

- Use the **Direct heating button (24)** to switch off the heating so that the **welding nozzle (18)** cools down.
- The **LED (23)** begins flashing at the heating button.



Only switch off the device with the **main switch (10)** when **LED (23)** stops flashing and disconnect the power supply cord from the electrical network.



Wait until the device has cooled down / LED has stopped flashing. If the cooling is not adhered to, the device may become damaged.

Check the power supply cord and plug for electrical and/or mechanical damage.

Clean the two filters of the **hot-air blowers (1)** and the **welding nozzle (18)** with a wire brush.

If the device is switched off without the cooling process being adhered to, the device may become severely damaged. No warranty or guarantee claims can be made for damage or malfunctions resulting from this.

7. Quick Reference Guide HEMTEK ST / K-ST



Risk of clamping injuries!

A danger of clamping injuries exists with the tilting mechanism when the hot-air blowers swivel in and out.



Risk of entanglement!

During operation there is a risk of entanglement on the drive roller.



Risk of burning!

Do not touch heating element, nozzle and components in the immediate vicinity of the nozzle when hot. The device should always first be allowed to cool down. Do not point the hot air flow at people or animals!





Switching on/Starting

1. Connect the mains voltage plug
2. Switch on the **main switch (10)**
3. Select/set the welding profile
4. Use the **direct heating button (24)** to switch on the heating / wait until the operating temperature has been reached (up to 5 min.)
5. Actuate the foot pedal or the **pressure button (21)**, hot-air blowers swivel in and the drive starts

Switching Off

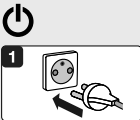
1. Actuate the foot pedal or the **pressure button (21)**, hot-air blowers swivel out and the drive stops
2. Use the **Direct heating button (24)** to switch off the heating.
3. **LED (23)** flashing (cooling down process)
4. **LED (23)** no longer flashing: Switch off the **main switch (10)**
5. Pull out mains voltage plug

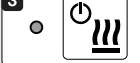
LEISTER HEMTEK ST / K-ST Quick Guide



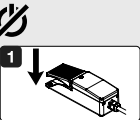
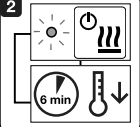
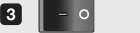
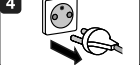



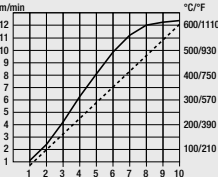

Temperature reference for HEMTEK ST / K-ST

Applicable:
100% air volume
230 V

Temp. ———
Speed - - - - -

User Manual:
leister.com/DLP-Hemtek-ST

QG HEMTEK ST/K-ST
Art. 156.698 / 07.2021

Temperature graph for 100% air volume and 230 V nominal voltage

8. Warning messages (HEMTEK ST / K-ST)

Message type	Display	Error description
Warning	Both LEDs, the Status LED Drive (20) and the Status LED Heating (23) are flashing.	Mains frequency error The air volume can no longer be adjusted.

9. FAQs, causes and measures (HEMTEK ST / K-ST)

Deficient quality welding result:

- Check drive speed, welding temperature and air volume.
- **Clean welding nozzle (18)** with wire brush (see chapter 6.7 Switch off device/maintenance).
- **Welding nozzle (18)** set incorrectly (see chapter 5.1 welding nozzle).
- **Guide (14)** set incorrectly (see chapter 5.2 Adjusting the guide)

After 5 minutes at the most, the set welding temperature has still not been reached:

- Inspect mains voltage.
- Reduce air volume.

Welding medium is not guided straight:

- **Guide (14)** set incorrectly (see chapter 5.2 Adjusting the guide).
- **Welding nozzle (18)** set incorrectly (see chapter 5.1 welding nozzle).
- **Table fastening (7)** is not mounted parallelly to HEMTEK ST / K-ST.
(see chapter 5.1 Setting and assembling table fastening)
- Guiding the material well by hand.

10. Accessories

Use only original Leister spare parts and accessories because otherwise no warranty or guarantee claims can be asserted.

You can find more information at www.leister.com.

11. Service and Repair

Repairs shall be assigned exclusively to authorized Leister Service points.

Leister Service points guarantee a professional and reliable repair service with original spare parts in accordance with circuit diagrams and spare parts lists. You will find the address of your authorized service center on the last page.

12. Training Course

Leister Technologies AG and its authorized service points offer welding courses and introductory training classes. You can find more information at www.leister.com.

13. Declaration of Conformity

EU Declaration of Conformity

Leister Technologies AG, confirms that this product in the model made available for purchase, fulfills the requirements of the following EU directives.

Directives: 2006/42/EC, 2014/30/EU, 2011/65/EU
Harmonized Standards: EN ISO 12100, EN 55014-1, EN 55014-2, EN 61000-6-2, EN 61000-3-2, EN 61000-3-3, EN 62233, EN 60335-1, EN 60335-2-45, EN IEC 63000

Kaegiswil, 04/14/2021

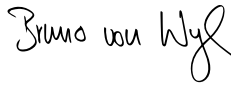

Bruno von Wyl, CTO



Christoph Baumgartner, GM

UK Declaration of Conformity

Leister Technologies AG, confirms that this product in the model made available for purchase, fulfills the requirements of the following UK Statutory Instruments.

UK Statutory Instruments: 2008 No. 1597, 2016 No. 1091, 2012 No. 3032
Designated Standards: EN ISO 12100, EN 55014-1, EN 55014-2, EN 61000-6-2, EN 61000-3-2, EN 61000-3-3, EN 62233, EN 60335-1, EN 60335-2-45, EN IEC 63000

Kaegiswil, 03/24/2021

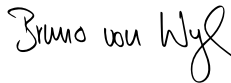

Bruno von Wyl, CTO



Christoph Baumgartner, GM

14. Disposal



Do not dispose of electrical equipment with household refuse.

Electrical appliances, accessories and packaging should be recycled in an environmentally friendly manner. When you are disposing of our products, please observe the national and local regulations.

Warranty

- The guarantee or warranty rights granted for this device by the direct distribution partner/salesperson apply from the date of purchase.
- In the event of a guarantee or warranty claim (verification by invoice or delivery note), manufacturing or processing errors will be rectified by the sales partner through replacement delivery or repair.
- Other guarantee or warranty claims are excluded within the framework of mandatory law.
- Damages resulting from natural wear, overload, or improper handling are excluded from the warranty.
- Heating elements shall be excluded from warranty obligations or guarantees.
- No guarantee or warranty claims exist for devices which have been converted or changed by the purchaser or for which non-original Leister spare parts have been used.

↳ Sales and service center



BA HEMTEK ST / K-ST
Art. 157.872 / EN / 11.2016 / 04.2022